



Your Texas Vivax-Metrotech Dealer:

**Indepth Utility Solutions LLC**

4100 Greenbriar Dr., Suite 240

Stafford, TX 77477

Phone: **281-969-8530**

Email: **info@indepthUS.com**

Website: **www.indepthUS.com**

**vLoc-9800 User Handbook**

(English Edition)

Version 1.1



# Table of Content

General Safety & Care Information .....	1
1.1 Who Can Use This Equipment .....	1
1.2 Work-site Safety .....	1
1.3 Equipment Safety .....	1
1.4 Batteries and Environmental Safety .....	1
1.4.1 Alkaline Batteries (Non Rechargeable) .....	1
1.4.2 Nickel Metal Hydride Batteries (Rechargeable).....	1
1.4.3 Lithium-ion Batteries (Rechargeable).....	2
1.4.4 Lithium Metal Batteries (Non Rechargeable).....	2
1.4.5 General Rules Regarding Disposal of Batteries .....	2
1.4.6 Transportation of Lithium-ion and Lithium Metal Batteries .....	2
1.5 Care of Equipment.....	2
1.6 Care When Interpreting the Information Provided by the Locator.....	3
1.7 American & Canadian Safety Notices.....	3
Service & Support .....	4
2.1 Serial Number and Software Revision Number .....	4
2.2 Distributors and Service Centers Closest to You:.....	5
vLoc-9800 Receiver .....	6
3.1 vLoc-9800 Receiver.....	6
3.2 Charging the Receiver Batteries.....	7
3.3 vLoc-9800 Receiver Display .....	8
3.4 Locating Mode (Response).....	8
3.4.1 Auto Left/Right Mode .....	8
3.4.2 Manual Left/Right Mode (Available on some models) .....	9
3.4.3 Manual Mode .....	9
3.4.4 Sonde Mode.....	10
3.5 Audio .....	10
3.6 Sensitivity Control.....	10
3.7 Setup Menu .....	11
3.8 Frequency Selection .....	11
3.9 Information Pushbutton (Depth & Current) .....	11
MyLocator2 .....	13
4.1 Launch the Application .....	13
4.2 Splash Screen .....	14
4.3 Software Update.....	15

4.4	Advanced Configuration Tool .....	16
4.5	Switch On/Off User Menu Settings .....	16
4.6	Switching On/Off Frequency Selections .....	17
4.7	Saving a Configuration .....	18
4.8	Configuration Lock Dongle .....	18
4.9	Icon Summary .....	19
Loc-10Tx Transmitter .....		20
5.1	Loc-10Tx Transmitter Overview.....	20
5.1.1	Transmitter Battery.....	21
5.1.2	Removing the Battery Tray.....	21
5.1.3	Replacing the Alkaline Battery .....	21
5.1.4	Rechargeable Batteries.....	21
5.1.5	Re-fitting the Battery Tray .....	22
5.1.6	Battery Charging and Disposal.....	22
5.1.7	Battery Condition Indication .....	22
5.2	Transmitting Modes .....	22
5.2.1	Induction Mode.....	22
5.2.2	Direct Connection Mode.....	23
5.2.3	Clamp Mode.....	24
5.2.4	Connection Block .....	24
5.2.5	Frequencies and Power Output.....	25
5.2.6	Most Used Frequencies (Frequency Selection) Feature .....	25
5.2.7	"Dual frequency" Mode.....	26
5.3	Information.....	27
Loc-5Tx Transmitter .....		28
6.1	Pushbutton .....	28
6.2	External Connectors .....	28
6.3	Transmitter Battery .....	28
6.3.1	Removing the Battery Tray.....	28
6.3.2	Replacing Alkaline Batteries.....	29
6.3.3	Rechargeable Batteries.....	29
6.3.4	Re-fitting the Battery Tray .....	29
6.3.5	Battery Charging and Disposal.....	29
6.3.6	Battery Condition Indication .....	30
6.4	Display.....	30
6.5	Multi Frequencies .....	31
6.6	Most Used Frequencies (Frequency Selection) Feature .....	31
6.7	Induction Mode .....	32

6.8	Direct Connection Mode .....	32
6.9	Clamp Mode .....	32
Loc-1Tx Transmitter .....		33
7.1	Pushbutton .....	33
7.2	External Connectors .....	33
7.3	Replacing Alkaline Batteries .....	33
7.4	Rechargeable Batteries .....	33
7.5	Loc-1Tx Transmitter Operation .....	33
Using the vLoc-9800 .....		34
8.1	Using the Receiver .....	34
8.1.1	Line Locating .....	34
8.1.2	Depth & Current Measurement .....	34
8.1.3	Sonde Location .....	35
8.2	Passive or Active Location .....	35
8.2.1	Passive Locating .....	35
8.2.2	Active Locating .....	36
8.3	Applying the Transmitter's Signal .....	36
8.3.1	Direct Connection .....	36
8.3.2	Clamp (Coupler) .....	37
8.3.3	Induction .....	37
8.3.4	Searching (sweeping) an Area .....	38
8.3.5	Tracing a Buried Line .....	38
8.3.6	Pinpointing & Confirming the Buried Line .....	39
8.3.7	Distorted Fields .....	39
8.3.8	Measuring Depth and Current .....	39
8.4	Using the Accessories .....	40
8.4.1	Using the LPC Separation Filter .....	40
8.4.2	Using the A-frame in Fault Finding .....	41
8.4.3	Using the Remote Antenna USB .....	43
Accessories & Options .....		45
9.1	A-frame (Optional) .....	45
9.2	Remote Antenna (Optional) .....	45
9.3	Loc-10Tx Vehicle Power Lead (Optional) .....	45
9.4	Loc-10Tx Outdoor Power Supply (Optional) .....	45
9.5	LPC Separation Filter (Optional) .....	45
9.6	Receiver Vehicle Charging Lead (Optional) .....	46
9.7	Sonde (Optional) .....	46
9.8	Clamp (Optional) .....	46

9.9	Lithium-ion Rechargeable Battery Pack (Standard).....	46
9.10	Receiver Battery Charger (Standard) .....	46
9.11	USB Cable (Standard).....	47
9.12	Alkaline Battery Holder (Standard) .....	47
9.13	Ground Stake (Standard) .....	47
9.14	Direct Connection Lead (Standard) .....	47
9.15	Loc-1Tx Alkaline Battery Tray (Standard).....	47
9.16	Ground Spool (Optional).....	47
9.17	Banana Plugs Adapter (Optional) .....	48
9.18	Loc-5Tx Battery Pack (NiMH).....	48
9.19	Loc-5Tx Alkaline Battery Tray.....	48
9.20	Loc-5Tx/10Tx Charger.....	48
9.21	Loc-10Tx Rechargeable Battery Tray.....	48
9.22	Loc-10Tx Alkaline Battery Tray.....	48
	Glossary.....	49

# General Safety & Care Information

## 1.1 Who Can Use This Equipment

- This equipment must only be used by people suitably trained in the use of pipe and cable locators.

## 1.2 Work-site Safety

- Use your companies, or other applicable safety code and rules when using this equipment.
- Unless having the required authorization, license and appropriate training – do NOT make connections to any pipe, cable or conductor.
- The equipment should not come in contact with corrosive or hazardous chemicals, or gases, dust.
- Do NOT directly connect this equipment to cables or pipes that have a potential difference to ground of greater than 35V AC.

## 1.3 Equipment Safety

- Do NOT open the enclosures (housings) of either the transmitter or receiver.
- Place the ground stake firmly in the ground before connecting the cable from the transmitter.
- Do NOT hold any uninsulated portion of the connection leads & clips when the transmitter is switched on.

## 1.4 Batteries and Environmental Safety

Vivax-Metrotech products use four types of batteries:

- Alkaline batteries
- Ni-MH (Nickel Metal Hydride) batteries – rechargeable
- Lithium-ion batteries – rechargeable
- Lithium metal batteries – (small non rechargeable button cells for “clock” applications)

### 1.4.1 Alkaline Batteries (Non Rechargeable)

- When replacing the alkaline batteries – use only the size and type specified – do NOT mix battery types (rechargeable and alkaline).
- Do NOT mix partially discharged and fully charged cells in the same battery pack – do NOT mix old with new.
- Never attempt to charge alkaline batteries.

### 1.4.2 Nickel Metal Hydride Batteries (Rechargeable)

- When using rechargeable batteries, **use only the correct charging device** supplied or specified by the manufacturer. The battery pack or the battery charger will contain circuitry to manage the charging process – other chargers (even if they have the same connector, polarity, voltage & current rating will not have the same control circuitry and can cause damage to the product, overheating, and in extreme cases fire or harm to the individual.
- Do NOT assume that if the plug fits it is the correct charger – a charger with the correct part number MUST be used – just because it is a Vivax-Metrotech charger and the plug fits does NOT mean it is the correct charger.
- Before using for the first time, charge rechargeable batteries for 6 hours. If at any time the rechargeable batteries do NOT last as long as anticipated – discharge fully and then charge for 6 hours.
- Care should be taken when charging batteries – NEVER repeatedly recharge batteries (or turn power off & on) without using the instrument. If used with an inverter in a vehicle – charge the product then unplug the charger and do NOT charge again until the rechargeable batteries have been used for at least ten minutes. Failure to do this could result in the overcharging of the battery which will shorten the life of the battery, and could in some circumstances cause overheating or fire.
- If ever the product becomes hot during the charging process IMMEDIATELY unplug the charger and use

## 1 General Safety & Care Information

the rechargeable batteries for at least 10 minutes before recharging. If this reoccurs the next time the unit is charged – return immediately to Vivax-Metrotech for repair.

- Do NOT charge batteries for prolonged periods of time without using the locator for at least 10 mins. Charging for prolonged period of time could overcharge the battery, reduce the battery life and in extreme circumstances cause damage to the locator and fire.

### 1.4.3 Lithium-ion Batteries (Rechargeable)

- Lithium-ion Batteries – some products use Lithium-ion batteries – the requirements for marking and transportation are still developing. Please contact Vivax-Metrotech before shipping products containing Lithium-ion batteries or Lithium-ion battery packs on their own for any “special instructions”.

### 1.4.4 Lithium Metal Batteries (Non Rechargeable)

- Commonly known as “button cells” these are small – non rechargeable batteries used to power internal “clocks” within some units (similar to computers). Generally they have a life of 3-5 years.
- Under no circumstances should any attempt be made to charge these batteries.
- Dispose of to your company’s work practice/environmental standards, the prevailing laws, or recognized best practice. Always dispose of batteries responsibly.

### 1.4.5 General Rules Regarding Disposal of Batteries

- NEVER disassemble a battery, or battery pack.
- Never dispose of in a fire or water.
- Dispose of batteries in accordance with your Company’s work practice/environmental standards, the prevailing laws, or recognized best practice. Always dispose of batteries responsibly.

### 1.4.6 Transportation of Lithium-ion and Lithium Metal Batteries

- The Lithium-ion and Lithium metal batteries used in Vivax-Metrotech products meet the required safety standards and include the designated protection circuitry.
- Recent regulation changes require that when batteries with Lithium-ion and Lithium metal batteries are transported the packaging MUST include specified warning labels. **Please contact Vivax-Metrotech Customer Service (USA 1-800-446-3392, International +1-408-734-1400 (USA Pacific Time Zone)) for more details.**
- Regulations have also changed regarding the shipping of spare battery packs (battery packs that are not inside a product). There are limitations on the weight of the package, and the packaging must be marked with the appropriate warning labels. **Please contact Vivax-Metrotech Customer Service (USA 1-800-446-3392, International +1-408-734-1400 (USA Pacific Time Zone)) for more details.**



#### IMPORTANT

**Remember – Batteries contain dangerous chemicals – They can be affected by many things such as water ingress or heat – In some circumstances they can explode. They also can cause electric shocks!**

## 1.5 Care of Equipment

- Use equipment only as directed in this User Handbook.
- Do NOT immerse any part of this equipment in water.
- Store in a dry place.
- Keep equipment in the case provided when not in use.
- If left for prolonged period of time – remove alkaline batteries.
- Keep unit clean and free of dust and dirt.
- Protect against excessive heat.

## **1.6 Care When Interpreting the Information Provided by the Locator**

- Like all locators – this instrument is locating, and providing depth and current readings based on electromagnetic signals that radiate from the buried cable or pipe. In most cases these signals will enable the locator to pinpoint both position depth and current correctly.
- BEWARE – in some cases other factors will distort electromagnetic fields radiating from cable or pipe being located, resulting in incorrect information.
- Always locate responsibly, and use information learned during your training to interpret the information provided by the locator.
- Do NOT provide information regarding depth of cable or pipe to anyone unless authorized to do so by your company.
- REMEMBER that depth measurements are to the center of the electromagnetic field or pipe – In the case of pipes this may be significantly deeper than the top of the pipe.

## **1.7 American & Canadian Safety Notices**

### **USA**

- This transmitter and receiver comply with the general conditions of operation, pursuant to part 15 of the FCC Rules.
  - CFR 47 Part 2
  - CFR 47 Part 15
- Changes or modifications not expressly approved by the manufacturer could void the user's authority to operate the products.

### **CANADA**

- Equipment is for use by trained operators only, and not for general household or consumer use.
- Operation is subject to the following two conditions: (1) this device may not cause interference, and (2) this device must accept any interference that may cause undesired operation of the device.

### **EUROPE**

- Vivax-Metrotech confirms that the location system is compliant with relevant provision of European directive 1999/5/EC.
  - ETSI EN 300 330-2
  - ETSI EN 301 489-1
  - ETSI EN 301 489-3
  - EN 55011
  - EN 61000-4-2 : A1 & A2
  - EN 61000-4-3
  - EN 61000-4-8 : A1



## Service & Support

### 2.1 Serial Number and Software Revision Number

Always quote your receiver and transmitter model number, serial number and software revision number when requesting product support. They can be found as follows: (for reference only)



1	Model & Serial Number
---	-----------------------



#### NOTE

The transmitter Model & Serial Number can be found at the bottom of the transmitter and also inside the transmitter between the battery tray and the main module of transmitter.

Software Revision Number: On both receiver and transmitter the software revision number is displayed on the LCD during the start up sequence. Or can be found in the “About” section of the user menu.

**2.2 Distributors and Service Centers Closest to You:**

United State of America	Europe
<p><b>Vivax-Metrotech Corporation</b> 3251 Olcott Street, Santa Clara, CA 95054, USA Website : <a href="http://www.vivax-metrotech.com">www.vivax-metrotech.com</a></p> <p>Sales &amp; Sales Support: T/Free : +1-800-446-3392 Tel : +1-408-734-1400 Fax : +1-408-734-1415 Email : <a href="mailto:sales@vxmt.com">sales@vxmt.com</a></p> <p>Application Support: T/Free : +1-800-624-6210 Tel : +1-408-454-7159 Fax : +1-408-743-5597 Email : <a href="mailto:applications@vxmt.com">applications@vxmt.com</a></p> <p>Service &amp; Repairs: T/Free : +1-800-638-7682 Tel : +1-408-962-9990 Fax : +1-408-734-1799 Email : <a href="mailto:service@vxmt.com">service@vxmt.com</a></p> <p>All Other Department: T/Free : +1-877-330-1647 Tel : +1-408-734-3880 Fax : +1-408-962-9993</p>	<p><b>SebaKMT</b> Seba Dynatronic Mess-und Ortungstechnik GmbH Dr.-Herbert-lann-Str. 6, 96148 Baunach, Germany</p> <p>Tel : +49-9544-680 Fax : +49-9544-2273 Website : <a href="http://www.sebakmt.com">www.sebakmt.com</a> Email : <a href="mailto:service@sebakmt.com">service@sebakmt.com</a></p>
<p><b>Canada</b></p> <p><b>Vivax Canada Inc.</b> 400 Esna Park Drive, Unit 17, Markham, Ontario, L3R 3K2, Canada</p> <p>Tel : +1-289-846-3010 Fax : +1-905-752-0214 Website : <a href="http://www.vivax-metrotech.com">www.vivax-metrotech.com</a> Email : <a href="mailto:CanadianSales@vxmt.com">CanadianSales@vxmt.com</a></p>	<p><b>Australasia</b></p> <p><b>SebaKMT AUS</b> Unit 1, 176 South Creek Road, Cromer NSW 2009, Australia</p> <p>Tel : +61-2-9972-9244 Fax : +61-2-9972-9433 Website : <a href="http://www.sebakmtaus.com">www.sebakmtaus.com</a> Email : <a href="mailto:sales@sebakmtaus.com">sales@sebakmtaus.com</a> <a href="mailto:service@sebakmtaus.com">service@sebakmtaus.com</a></p> <p><b>China</b></p> <p><b>Leidi Utility Supply (Shanghai) Ltd.</b> Rm405 3<sup>rd</sup> Building No. 641, Tianshan Rd, Shanghai, China 200336</p> <p>Tel : +86-21-5187-3880 Fax : +86-21-5168-5880 Website : <a href="http://www.leidi.com">www.leidi.com</a> Email : <a href="mailto:info@leidi.cn">info@leidi.cn</a></p>

## vLoc-9800 Receiver

### 3.1 vLoc-9800 Receiver

The vLoc-9800 is a Precision Location System designed to meet the needs of Utility Companies and their contractors. The following describes the features and use of the receiver:



1	Bluetooth Module (Not available for vLoc-9800)	6	Charging Socket
2	Pushbutton & Display	7	Mini USB Port Data Transfer and Software Upgrade
3	Carbon Fiber Reinforced Antenna Assembly	8	Accessories Port
4	Accessory & Charging Sockets	9	Model# & Serial#
5	USB Data Transfer (Inactive)	10	AA Battery Pack/Rechargeable Battery Pack

### 3.2 Charging the Receiver Batteries

The vLoc-9800 can be used with either alkaline batteries or it can be supplied with an interchangeable rechargeable battery pack.

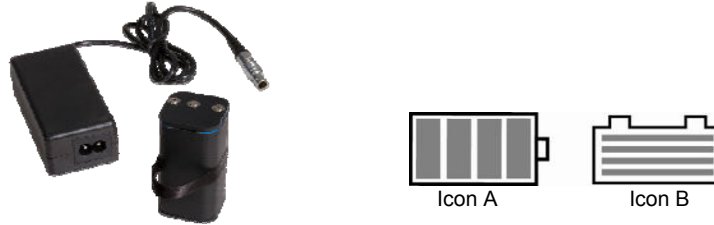

When alkaline battery is used, Icon A will appear on the screen. When the rechargeable battery pack is used, Icon B will be displayed.

In both cases, the number of bars illuminated within the battery icon indicates the amount of charge remaining.

Rechargeable batteries are supplied with a mains charger. This is specific to the batteries, avoid the use of other manufacturers' chargers as these may damage the battery pack and may result in overheating of the battery pack.

To charge the rechargeable batteries, first make sure the pack is inserted in the receiver battery compartment as charging is done inside the receiver.

Connect the charger to the charging socket of the receiver. Connect charger to the mains and switch on. The LED indicator on the charger will illuminate red until the batteries are fully charged at which time the LED will change to green.



#### **WARNING**

**Rechargeable batteries are supplied with a mains or 12V DC charger. These are specific to the batteries. Only use the charger that is appropriate for the batteries in the product. If in doubt, call Vivax-Metrotech Customer Service. Failure to use the appropriate charger could result in damage to the battery pack, locator and in extreme cases cause fire.**

**Avoid charging the unit in extreme temperature conditions. (i.e. below 0°C and above 45°C)**

**Although Vivax-Metrotech batteries include all the required safety related features always immediately discontinue use of the charger and battery pack if the battery pack becomes excessively warm. Return both to where they were purchased for investigation.**

**Always ensure batteries have at least a partial charge if storing for long periods without use.**

**Dispose of all batteries in accordance with your company procedures and Federal/State and local regulations.**

**Never dismantle batteries, put them in fire, or get wet.**

### 3.3 vLoc-9800 Receiver Display

The vLoc-9800 has two operational displays, “Left/Right” and “Peak Detect”.

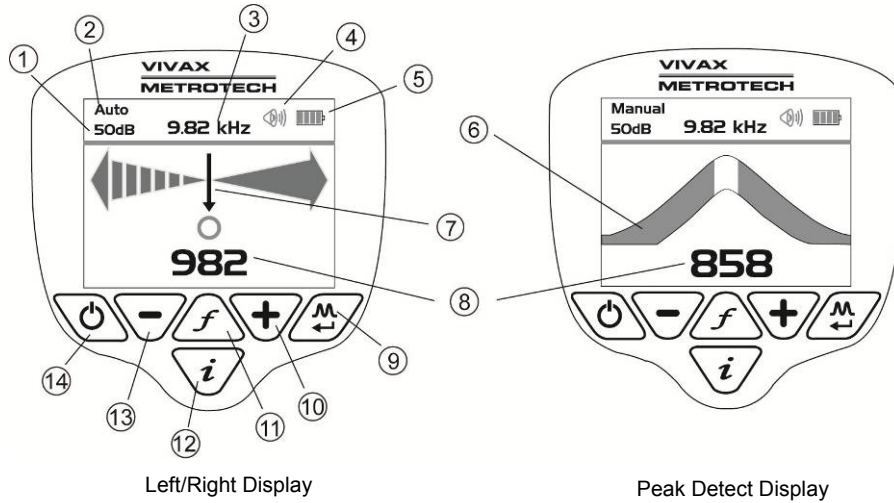

1	Sensitivity Setting	8	Signal Strength
2	Auto/Manual/Sonde Indicator	9	Mode Select, Auto/Peak/Sonde
3	Frequency	10	Increase Sensitivity
4	Speaker Volume	11	Change Frequency
5	Battery Level	12	Information Key (selects depth screen for instance)
6	Signal Strength Bar Graph	13	Reduce Sensitivity
7	Moving Pointer	14	On/Off Switch

### 3.4 Locating Mode (Response)

The vLoc-9800 receiver has an array of antennas; these can be toggled through different configurations (modes) to provide different responses to the signals radiating from the buried pipes and cables. The modes are:

#### 3.4.1 Auto Left/Right Mode

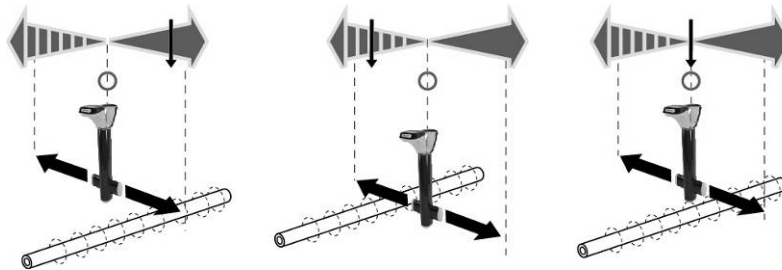
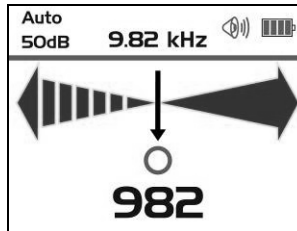

The Left/Right Auto mode is ideal when tracing long distance lines in less congested sites. It requires no user input to the keyboard allowing the operator to concentrate more on the safety of the surroundings.

As the locator is moved from left to right across the cable the moving bar will move accordingly. When the moving bar is directly over the circle (indicating the cross section of a cable or pipe), the locator is directly over the target line. At this point the numeric signal level will be at its highest.



**NOTE**

The tone from the speaker is pulsing one side and has a solid tone the other. This is to enable the operator to easily judge the position of the line without looking down at the display when walking along busy streets etc.

When operating in the Auto Left/Right mode the dB sensitivity value will be continuously changing. This is because the unit is automatically adjusting the gain of the instrument to optimize the performance in that situation.

**3.4.2 Manual Left/Right Mode (Available on some models)**

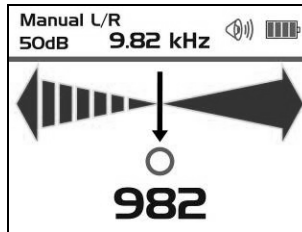

In the Manual Left/Right mode the sensitivity is set by pressing the "+" and "-" pushbuttons. This has the advantage of enabling the operator to adjust the sensitivity balance on signals from a deep pipe or cable. It can also be used to mask out the signal from an unwanted source.

To reject an unwanted signal, first set the sensitivity to a high value such that the unwanted signal is detectable. Sweep across the unwanted signal, reducing the sensitivity until the locate bar ceases to respond to the signal. Now double check that the wanted line is detectable. Keep the sensitivity at this setting and continue to locate the line.

**3.4.3 Manual Mode**

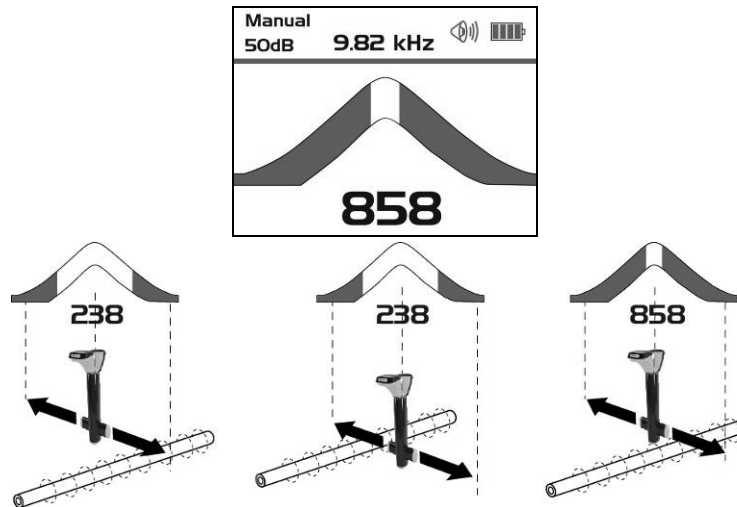

The Manual mode is particularly useful in congested areas where there are multiple signals radiating from various lines. The sensitivity is set manually by pressing the "+" and "-" pushbuttons. As the locator is traversed across the target line the "curtains" of the bar graph will close. If the curtains are fully closed or fully open, one press of the "+" or "-" will bring the curtains back within scale. A numeric signal level is also displayed.

When using the manual mode the relative signal levels become apparent aiding identification of the target line.

### 3.4.4 Sonde Mode

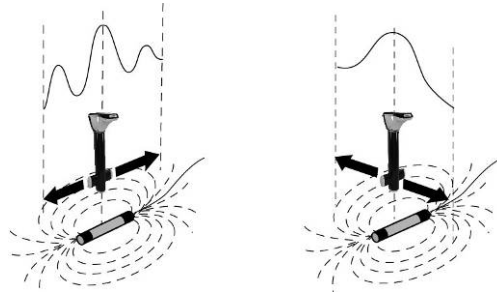
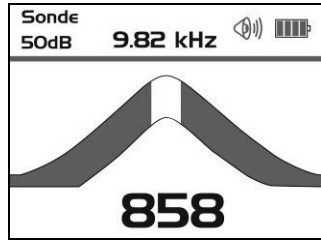

Sonde mode uses the antennas in a “Peak” configuration. Text on the display indicates if the receiver is in Sonde mode.

A Sonde is a small transmitting coil that is powered by its own internal battery, or by an external transmitter.

Due to its construction, a Sonde gives a different “Peak” pattern – when locating along the direction of the Sonde – instead of the usual single “Peak”, the Sonde provides three distinct peaks – a small “Peak” – a large “Peak” – a small “Peak”. The Sonde is located under the center of the large “Peak” when located across the direction of the Sonde and it gives the conventional peak response.

The vLoc-9800 receiver must be used in a different orientation when locating a Sonde – due to the way the signal from the Sonde radiates. With the front of the receiver pointing across suspected direction of the Sonde – pinpoint forward and backward (across the Sonde) and then move along the line of the Sonde until the maximum peak is located (in other words rotate the receiver 90° from the orientation normally used when locating pipes and cables).

A Sonde is typically used for locating non metallic pipes or ducts, and the camera end of a sewer inspection camera. Low frequency versions (512Hz/640Hz) can transmit through some metallic pipes such as cast iron pipes – which is why they are frequently used with sewer inspection cameras.

### 3.5 Audio

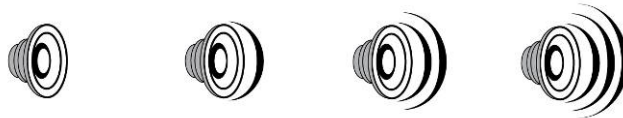

The visual display is also accompanied by an audio response. The output level (volume) of this response is set by entering the “Menu”. Press and hold “i” pushbutton for 2 seconds to enter setup menu. The setup display defaults to volume. Use the “M” pushbutton to toggle through the available options (Off – Low – Med – High). Press the “i” pushbutton again to exit the setup menu. As the loudspeaker uses a significant amount of power, using lower volume can make the battery life of the receiver last longer.

### 3.6 Sensitivity Control

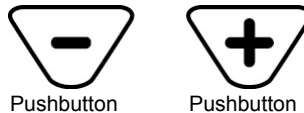

In manual modes, up & down pushbuttons are provided to increase or reduce the sensitivity of the receiver. If the bar graph moves towards the minimum or maximum a single touch of the opposite pushbutton returns it to approximately 50% deflection. Holding down or repeated pushing of the “+” or “-” pushbuttons increments/decrements the gain.

### 3.7 Setup Menu

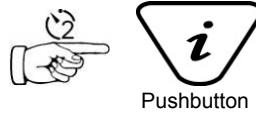

A second function performed by the “i” pushbutton is to access the setup menu. Press and hold the “i” pushbutton for two seconds to display the setup menu. Use the “+”, “-” to navigate through the various options and use the “M” pushbutton to select. To exit the setup menu, press the “i” pushbutton.

The setup menu allows the user to configure their personal preferences. This menu can be accessed and changed at any time.

### 3.8 Frequency Selection

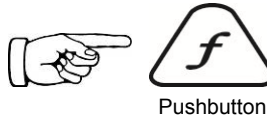

The vLoc-9800 receiver is capable of locating a number of frequencies. A list of these frequencies can be accessed using the setup menu. The setup menu allows the operator to select the frequencies they wish to use regularly. The frequency select pushbutton on the main receiver pad is used to toggle through the frequencies defined in the setup menu. The operating frequency is shown in the information bar at the top of the display. It is possible to change this selection at any time using the setup menu.

The initial frequencies set at the time the unit is supplied are “Power”, “Radio”, 982Hz, 9.8 kHz, and 83.1 kHz. See the transmitter section for suggestions of which frequency is best suited to specific applications.

To select the frequencies you wish to use regularly, enter the setup menu by pressing and holding the “i” pushbutton for 2 seconds. Use the “+” and “-” to select the word “Frequency” – then press the “M” pushbutton to display the list of available frequencies.

The “+” and “-” pushbuttons are used to navigate the list of frequencies. To add a frequency to the “Frequently used list” press the “M” pushbutton and a dot will appear in the circle alongside the frequency. To deselect a frequency press the “M” pushbutton and the dot will disappear. Once your selection is completed press “i” pushbutton once to return to the setup menu, and again to exit the setup menu.

### 3.9 Information Pushbutton (Depth & Current)

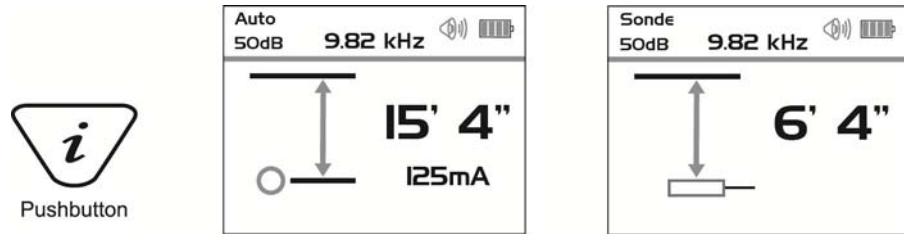

Pressing the “i” pushbutton will display the depth to the center of the radiated signal and a measurement of the current (press the pushbutton briefly – remember if you press and hold, you enter the setup menu. If you do enter the setup menu, press the “i” pushbutton again to return to the locating screen then try again).

If measuring the depth of a Sonde, ensure “Sonde” mode is selected otherwise the depth measurement will be incorrect. Sonde mode has a different “Depth” screen and does not indicate current.



**IMPORTANT**



When locating a cable or pipe (“Line”) – the instrument should be in “Peak” or “Left/Right” mode and the depth and current measurements should only be taken with the bottom of the receiver standing on the ground and directly in line with the target line.

When locating a Sonde – set the mode to Sonde - then the instrument will automatically be in “Peak” configuration. Depth measurements should only be taken with the bottom of the receiver standing on the ground and at ninety degrees to the Sonde.

The accuracy of depth and current readings depends on the quality of the radiated signal being located. If the signal is not distorted, the depth reading will be accurate to within 5% of the actual depth. If the signal is distorted, depth readings will be less accurate. When taking depth measurement, always hold the receiver in line with the line and at 90<sup>0</sup> to the ground.

## MyLocator2

MyLocator2 configuration tool is a software package that enables the operator to configure vLoc series 2 locators. The software is compatible with Window XP, Vista and 7. To install, use the link on the Vivax-metrotech web site and follow the installation instructions. A MyLocator2 shortcut icon will appear on your desktop.

MyLocator2 is under continual development so the following is a guide to its operation but there may be subtle changes to screens etc. However, the guide should still give sufficient information for the user to navigate MyLocator2.

### 4.1 Launch the Application

To launch MyLocator2, double click on the MyLocator2 shortcut icon. If the host computer is connected to the web, it will check to see if MyLocator2 is the latest version. If it is not, it will ask if you wish to install the latest version. Follow the instructions if you wish to install the new version.

MyLocator2 can be operated on different levels. Each level enables different features and functionality. Some levels require a dongle to operate. Dongles are available from Vivax-Metrotech.

In its basic form it allows the operator to:

- Check the software revision number and download the latest version. This feature is useful where software changes have been made to enhance existing features and to install new free of charge features as they become available.
- Adding flash screens: The user can add pictures or company Logo's of his choice to the start up screen.

The basic operational screen is displayed below.



Connect the vLoc-9800 Receiver to the PC using a USB to Mini USB cable. The PC should recognize the vLoc-9800 and the display will now change to the below or similar.

## 4 MyLocator2

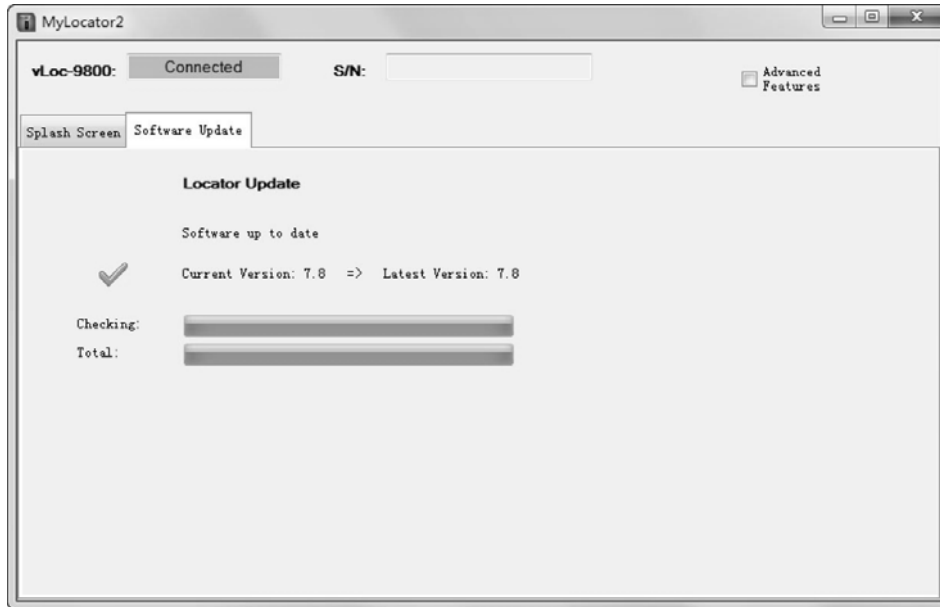

If connected to the web, MyLocator2 will check at this stage to see if there is a newer version of MyLocator2 or locator software is available. If it is and you wish to update either software follow the instructions.

The configuration of the locator can be saved at any time as described below in section 4. However, MyLocator2 will occasionally prompt the user to save a configuration. It is not necessary to save a configuration at these times unless the user will find the configuration useful at a later date.

It will now be possible to perform the 2 operations in the tabs shown.

### 4.2 *Splash Screen*

1. Click the Spash Screen tab. Click on the "Open" button. Browse your computer to find the picture that is intended to be the splash screen.
2. The software will accept the following formats: JPEG, BMP, GIF, PNG, ICO.
3. Select the file and open. The screen below should now also contain a representation of the picture.
4. Press "Download" to transfer the file to the vLoc or "Clear" to remove the file.
5. Clicking on "Scale to LCD" will alter the aspect ratio of the picture to fully fill the screen. Leave this unchecked if no scaling is required. Check the "Centre" button to centre the graphic on the screen.

## 4 MyLocator2



6. Text can also be added to the flash screen.
7. Use the "Text", "BG Color" (Background color) and "Font" buttons to add text to the start up flash screen.

### 4.3 Software Update

1. With the locator switched on and connected to the computer, click on the "Software Update" tab.
2. A screen similar to the one below should be shown.

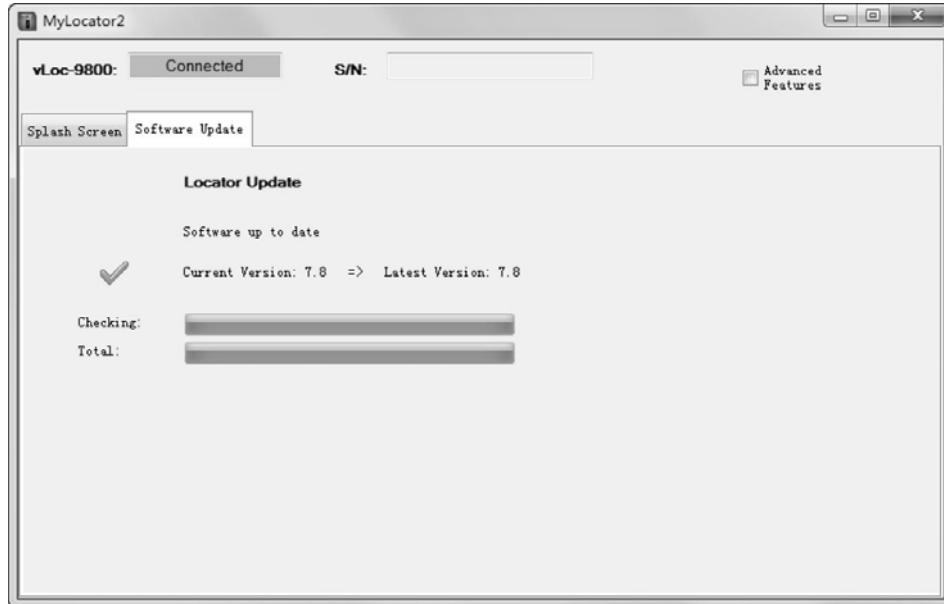

3. If connected to the Web, MyLocator2 will indicate if a newer version of software is available. If you wish to download it select "Yes" in the dialogue box.
4. The progress bars below will start to activate showing the progress of the software installation. When it is complete a message "software download complete" will be shown both on the computer and locator screen.
5. Note that the new software will not be active until the unit has been switched off and on again.

#### 4.4 Advanced Configuration Tool

Clicking the “Advanced” button allows the user to configure the instrument to specific requirements.

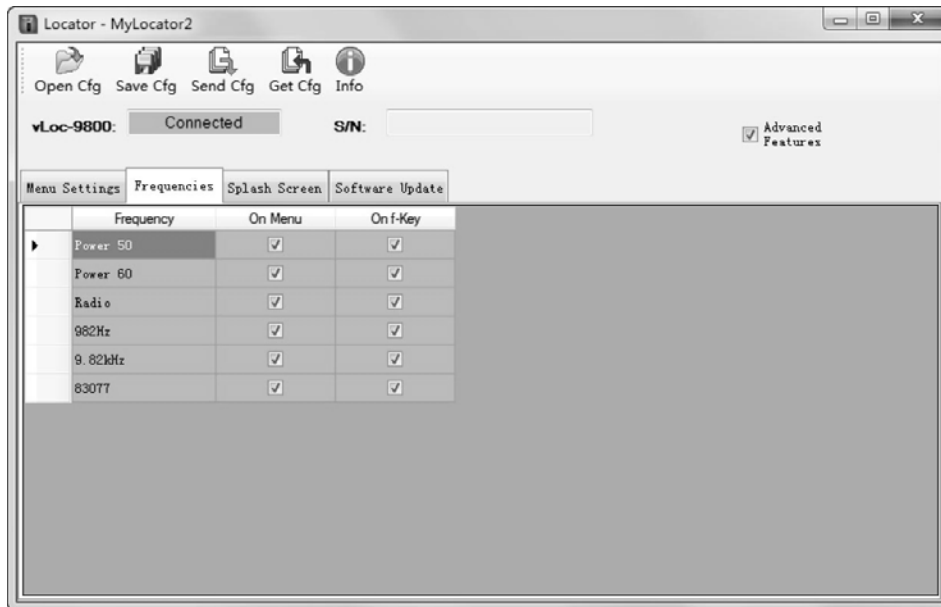

The features available are:

- Switch on or off user menu settings
- Switch off frequency selections

By doing this, the locator is simplified and tailored exactly to the customer requirements.

The configuration can be saved as a “config” file and used to configure other vLoc-9800 locators. This ensures consistency throughout the locator fleet.

#### 4.5 Switch On/Off User Menu Settings

1. With the locator switched on and connected to the host computer click on the “Menu Settings” tab.
2. A screen similar to the one below should be shown. If not, click on the “Get Cfg” icon on the top bar. This will load the configuration of the connected locator to the host pc.

## 4 MyLocator2

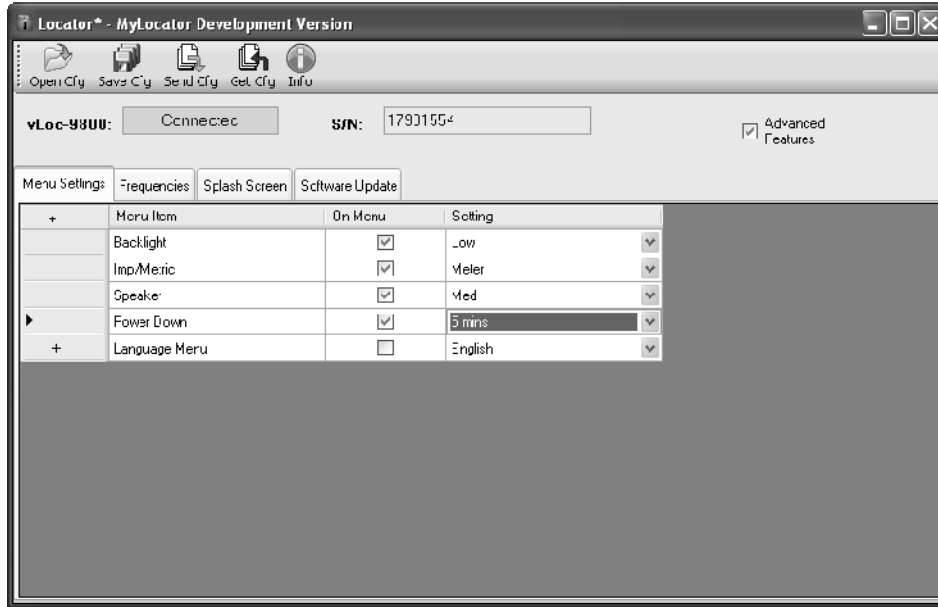

3. Check the boxes that are required to be made available.
4. Click on the pull down menu and select the settings required.
5. Clicking on the "Send Cfg" icon will send the configuration to the locator.

### 4.6 Switching On/Off Frequency Selections

1. Click on the "Frequencies" tab. A screen similar to the one below should be shown.

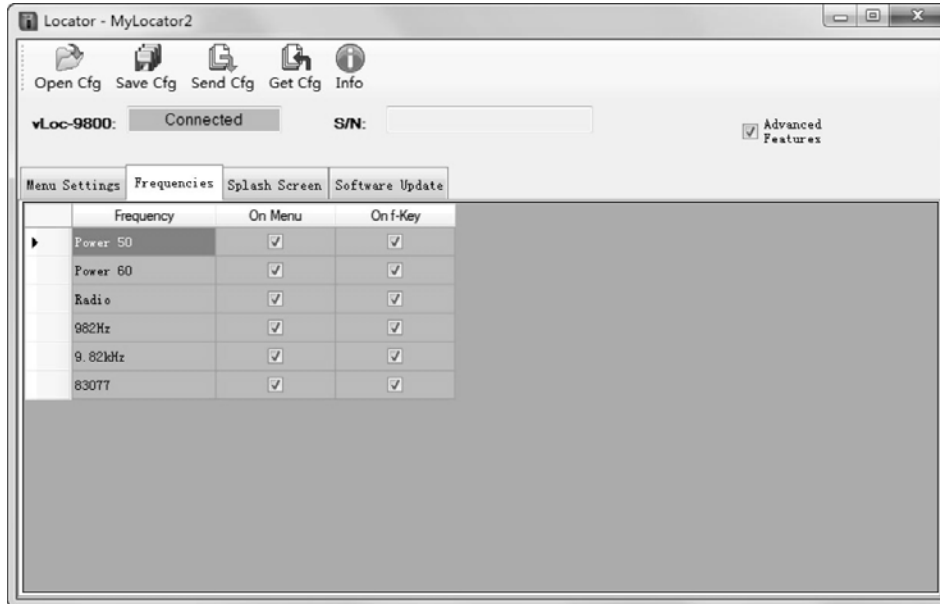

2. Each row is color coded:
  - **Grey** indicates that frequency is not selected for either the menu or the frequency key.
  - **White** indicates that the frequency will be active in the locator menu but has not been selected to show on the frequency key. (Note that it is still possible to make this frequency available on the locator by selecting it in the locator frequency menu.)
  - Green indicates that the frequency will be available both in the locator menu and frequency select key.

## 4 MyLocator2

- **Blue** shows active line.
3. Make the selections required.
  4. Clicking on the “Send Cfg” icon will send the configuration to the locator.

### 4.7 Saving a Configuration

Having created a configuration it is possible to save this for future use.

#### To save a configuration:

1. Click on the “Save Cfg” icon.
2. Browse to a desired file location.
3. Create a name for that file, the extension will be: filename.vmcfg.
4. Press “Save” in the window.

#### To retrieve the file:

1. Click on the “Open Cfg” icon and browse to select the desired file.
2. Click on “open” in the window.
3. The file will populate the MyLocator2 screen automatically with the settings from the configuration file.

### 4.8 Configuration Lock Dongle

A Configuration Lock dongle is available that allows “lockout” of features and functions so that operators are forced to use particular settings. The dongle is also used to unlock these features.



To activate the dongle, plug it into any USB socket on the host computer.

With the dongle active, the MyLocator2 screen will look similar to the picture below.

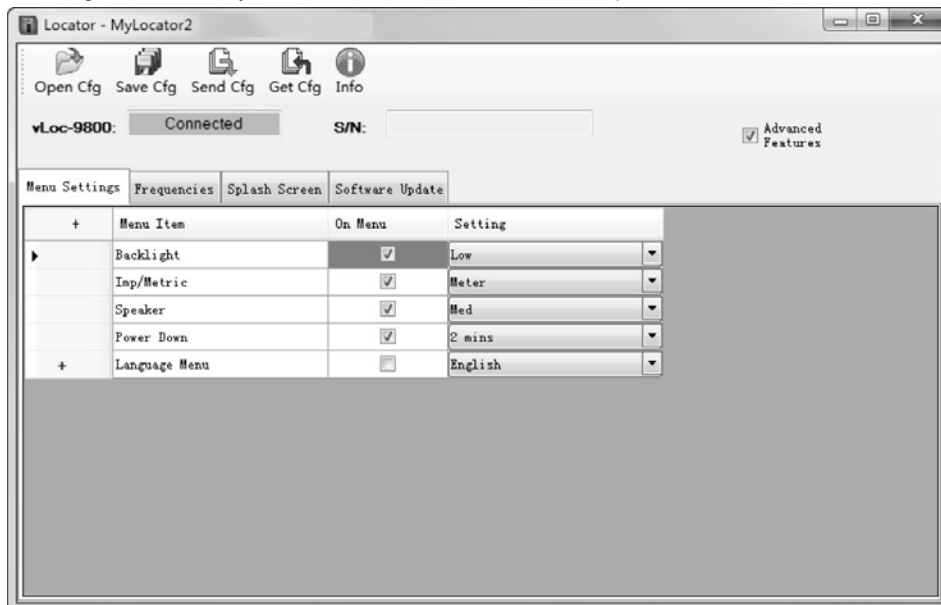

Note the padlocks on the three tabs, Menu Settings, Frequencies and Splash Screen.

When a locator is configured with these locks activated, the menu and frequency options in the locators user menu will not appear, stopping the user from altering the settings downloaded to the locator by the Dongle activated MyLocator2 facility.

To activate the padlocks simply double click on the desired tab.

The features can only be re activated by connecting to a host computer with MyLocator2 which has been

## 4 MyLocator2

dongle activated. Double click on the padlocks as before to unlock them and download the changes to the locator.

### Example use of the Dongle Lock:

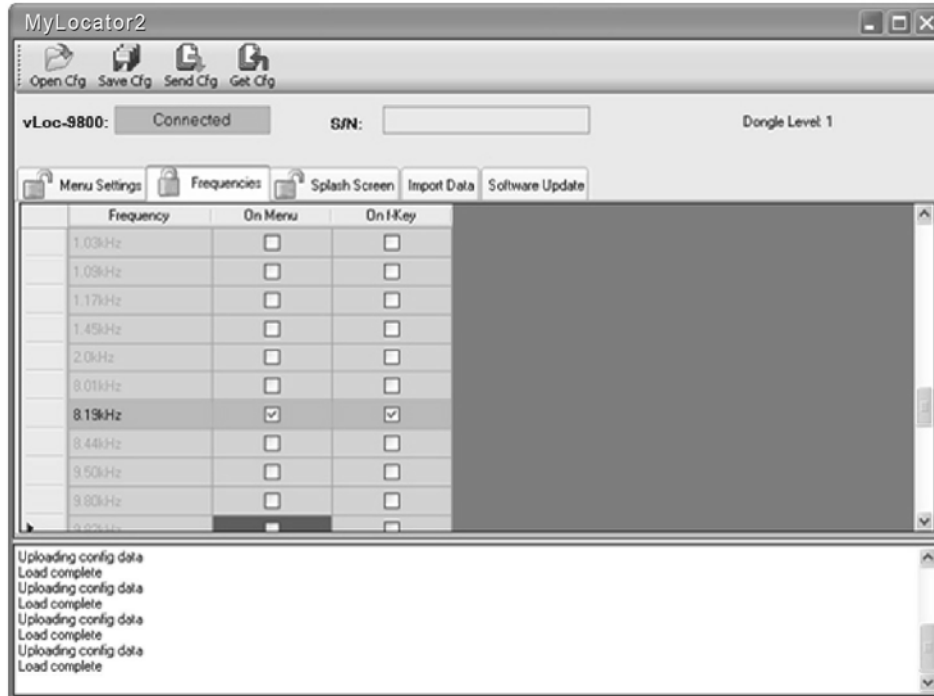

Supposing the Dongle User wishes to force the user to only use 9.82 kHz. The operation would be:

1. Connect the locator to the host computer and switch on. Launch MyLocator2.
2. Click on the "Get Cfg". This will populate MyLocator2 with the Locators configuration.
3. Click on the "Frequency" tab.
4. Uncheck all frequencies except 9.82 kHz.
5. Check both boxes associated with 9.82 kHz as below.
6. Double click on the Frequency tab to lock the padlock.



7. Now click on the "Send Cfg" icon to send it to the locator.
8. To activate the new configuration switch the locator off and on.

## 4.9 Icon Summary

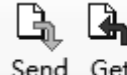
Icon	Function
 Open Cfg	Opens a previously saved configuration.
 Save Cfg	Saves a configuration created by the operator to a file of your choice.
 Send Get	Either "Send" (saves) configuration to a locator or "Get" (copy) a configuration from a locator.



# Loc-10Tx Transmitter

## 5.1 Loc-10Tx Transmitter Overview

The Loc-10Tx transmitter is a rugged portable transmitter powered by alkaline "D" cells or Ni-MH (Nickel Metal Hydride) rechargeable batteries. The following describes the features and uses of the transmitter.

### Display

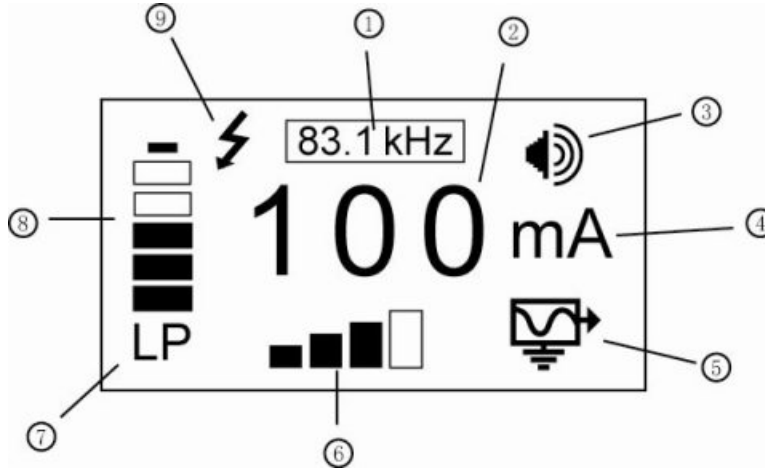

1	Frequency Being Transmitted (200 kHz available in some country)	6	Output Setting (Step) (filled box indicates current level has been reached, empty box indicates requested current level has not been achieved)
2	Digital Read Out (mA, volts, ohms)	7	Low Power Indicator (enabled automatically when battery becomes one bar)
3	Loudspeaker Level	8	Battery Status
4	Units (mA, volts, ohms)	9	High Voltage Warning (output is enabled for high voltage)
5	Mode Indication		

### Pushbutton

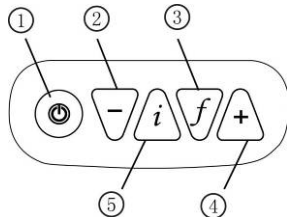

1	On/Off Control
2	Output Decrease
3	Frequency Select
4	Output Increase
5	Information (Volume, mAmps, volts, ohms)

### Connections

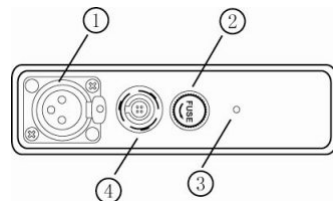

1	Output Connection
2	Output Protection (Fuse)
3	Loudspeaker
4	Battery Charging Socket & DC Input

**5.1.1 Transmitter Battery**



In most markets the transmitter is shipped with alkaline batteries (12 x D cells) unless rechargeable batteries are specified. Batteries are fitted into quick release trays – the alkaline is an open pack, to enable the batteries to be changed. The rechargeable pack is a sealed unit containing Ni-MH (Nickel Metal Hydride) batteries. These packs can only be fitted in a manner to ensure that the alkaline batteries cannot be inadvertently charged.

**5.1.2 Removing the Battery Tray**

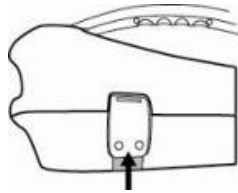

Push up button

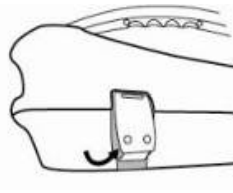

Pull out bottom of catch

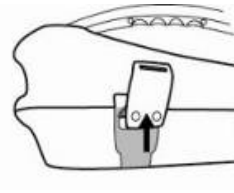

Lift up catch until it clears catch plate

**5.1.3 Replacing the Alkaline Battery**

- To access batteries – undo stainless steel screws on each battery cover
- To remove batteries – turn tray upside down and give a short sharp tap of the battery tray on your hand
- Replace batteries with new batteries of the same type, be sure not to mix old and new batteries
- Do NOT use rechargeable batteries in the alkaline battery tray. Ensure that batteries are inserted the correct way (see label and molded “+” and “-” in the bottom of the tray)
- Refit the battery cover – then refit the battery tray

**WARNING**

Alkaline Batteries – insert alkaline batteries (x12) as shown:

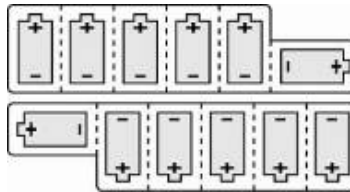

**5.1.4 Rechargeable Batteries**

- Do NOT attempt to replace the rechargeable batteries or remove battery covers – return to Vivax-Metrotech or a Vivax-Metrotech approved service centers for replacement.



**WARNING**

Use only Vivax-Metrotech recommended charger.

### 5.1.5 Re-fitting the Battery Tray

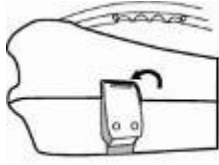

Place top of catch over catch plate

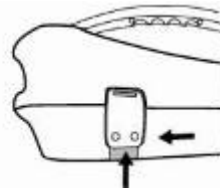

Push up button underneath the catch – where holding that up push in the bottom of the catch. You will hear a positive “click” (Do NOT force catches)

To close battery tray – slid transmitter (TX) onto tray, it will locate itself in the correct position, then close the catches.



**WARNING**  
Power “IN” socket

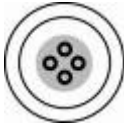

**Two pins are used for power in from charger (to charge rechargeable batteries). Two pins are used for power from external 12V DC source. A 12V DC power cable is supplied and is designed to be connected to an automobile cigarette lighter socket.**

Contact Vivax-Metrotech or a Vivax-Metrotech approved service center for wiring diagram of plug, if attempting to repair any of the “charging” leads.

### 5.1.6 Battery Charging and Disposal

Follow instructions detailed in the General Safety & Care portion of this document.

Only use the battery charger supplied. Using a non approved charger may damage the battery pack and could cause overheating.

To charge, the batteries must be connected to the transmitter. Connect the mains charger to the charging socket on the side of the transmitter and connect the charger to a suitable mains socket.

The LED will show a red light indicating that the charge cycle is in progress. When the batteries are fully charged the LED will change to green.



**NOTE**  
Rechargeable pack cannot be charged from a 12V DC source.

### 5.1.7 Battery Condition Indication

The battery condition (charge) is displayed on the left side of the display, in the case of the rechargeable batteries the condition is also indicated on the charger (red/green light).

## 5.2 Transmitting Modes

The transmitter has three transmitting modes, which are selected automatically.

### 5.2.1 Induction Mode

This uses an internal antenna to induce a locating frequency onto the target pipe or cable (line). “Induction” mode is automatically selected if no connection accessories are plugged into the “output socket”. An icon indicating “Induction” mode shows on the display. The icon flashes when the transmitter is transmitting. In order to generate successful induction, the transmitter should be positioned over and with the handle in line with the target line.

## 5 Loc-10Tx Transmitter

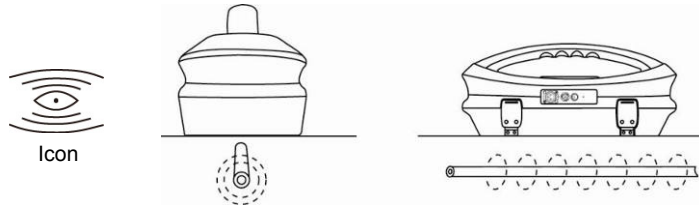

"Induction" mode is generally used when no access is available to make a direct connection, or a clamp connection. When using induction it is very likely that the signal being induced onto the target line will also be induced onto other lines in the area, and onto above ground features such as wire fences. This can influence the accuracy of the location, depth and current measurements. "Induction" mode is also the least efficient way of applying the transmitting signal to the target line. The distance located with "Induction" mode is generally much less than that achieved with a direct connection or clamp connection. "Induction" mode generally works better in higher frequencies, 33 kHz, 65 kHz and either 83.1 kHz or 200 kHz (depending on region). The advantage of induction is that no access is required to "connect" the transmitter, making it a very quick process. The antennas on the transmitter are tuned to induce specific frequencies or range of frequencies. Therefore only a limited number of frequencies can be selected in "Induction" mode.



### NOTE

**For accurate location and depth measurement the locator receiver should be used no closer than 50ft (20m) from the transmitter.**

### 5.2.2 Direct Connection Mode

By plugging in a connection lead to the output socket, "Direct connection" mode is selected. An icon confirming this is shown on the display. The icon flashes when the transmitter is transmitting. The direct connection lead consists of two cables, one (red clip) must be connected to the conductor being located, the other (black clip) to a suitable ground (a ground stake is provided with the transmitter). An auxiliary ground lead is also supplied. If the auxiliary ground lead is used, the ground clip of the connection lead (black clip) is attached to one end of the auxiliary ground lead.

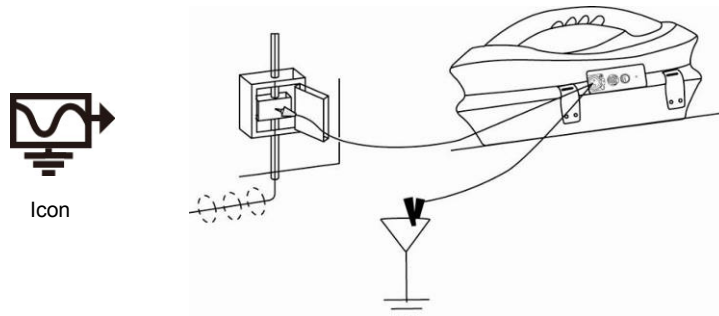

Wherever a direct connection can be safely made without the risk of injury, damage to customer's plant, or the transmitter, it is the best way of applying the transmitter's signal.

The coupling of the transmitted signal to other pipes and cables in the area will be much less than with induction, although where commonly bonded systems are encountered – coupling cannot be avoided.

The positioning of the ground connection can also influence the degree of coupling experienced. Ground connections generally should not be made to other pipes or cables, or above ground metallic structures such as wire fences. In general the lower the frequency is, the further the signal will travel, and the less signal coupling will occur. The most common frequencies used for direct connection are between 512 Hz/640 Hz and 8 kHz.

Regulations in many countries require that power output is limited above certain frequencies. The Loc-10Tx enables frequencies below 45 kHz to be transmitted using as much as 10 watts output, but frequencies over 45 kHz are restricted to 1 watt. Using direct connection and the higher power at the low frequencies helps significantly in achieving greater location distances. Direct connections should not be made to cables carrying greater than 35 volts (or as your safety practices allow). The transmitter is protected (250V fuse) from stray currents that may exist on the target line.

### 5.2.3 Clamp Mode

Plugging the signal clamp supplied by Vivax-Metrotech into the output socket will place the transmitter in “Clamp” mode. An icon confirming this is displayed on the display. The icon flashes when the transmitter is transmitting. When using the clamp no ground connection is needed.

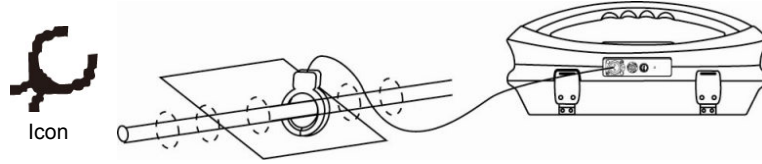

The clamp again is a precise way to apply the locating signal. It is generally used when access to the conductor cannot be achieved to make a direct connection (but there is sufficient access to place the clamp around the cable), or when it is not safe to make a direct connection because the target cable is carrying electricity.

The clamp is a specialized inductive device (sometimes known as a toroid or coupler). All clamps are optimized to work at specific frequencies. In most cases clamps are designed to be used at up to three frequencies only, generally between 8 kHz and 85 kHz. The transmitter will only allow the selection of a suitable frequency for your clamp.



**WARNING**

**When applying the clamp to cables that carry electricity – be sure to follow your company’s safety instructions and procedures. Beware that if applied around a high voltage cable – that cable may induce a current in the clamp causing it to snap shut or jump quite dramatically – always apply clamps carefully.**

### 5.2.4 Connection Block

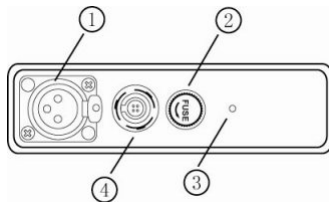
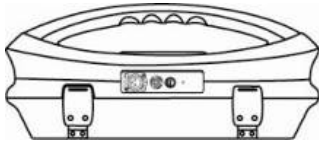

1	Output Connection
2	Output Protection (Fuse)
3	Loudspeaker
4	Battery Charging Socket & DC Input

All the connections made to the transmitter are made at the connection block except for a USB socket which is mounted inside the battery compartment and is used for programming the transmitter’s processor.

The connection block consists of:

- Output (XLR) socket – for the direct connection lead and clamp.
- Charger socket (to allow the retrofitting of a rechargeable battery pack – the charging socket is present even if re-chargeable batteries have not been purchased).
- Transmitter 12V DC power lead used to power the transmitter from a vehicle (NOT for charging).
- Fuse – this protects the transmitter circuitry in the event of the transmitter receiving up to 250V incoming on the output leads.
- A beeper is positioned behind the small hole.

### 5.2.5 Frequencies and Power Output

The Loc-10Tx transmitter is supplied with a predefined set of transmit frequencies.

Standard frequencies are:

- 982Hz – 10 watts, 5 watts, 1 watts
- 9.80 kHz – 10 watts, 5 watts, 1 watts
- 83.1 kHz – 1 watt

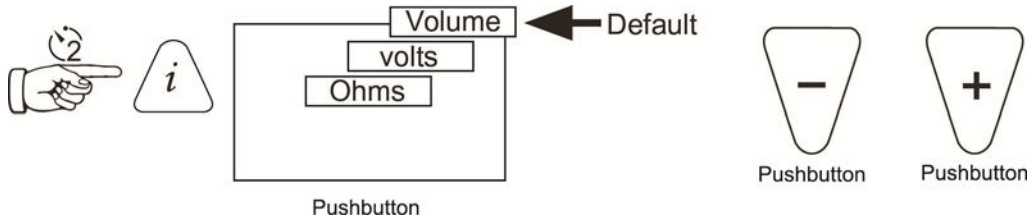

As with most manufacturers the clamps and induction antennas are tuned to specific frequencies, and do NOT work over the complete range.

Frequencies are selected by pressing the "f" pushbutton which toggles through the available frequencies for the selection mode. The frequency is automatically selected if you don't toggle past it within 2 seconds. The frequency is shown on the display.

The output current is shown in large characters on the display – to increase or reduce the power output press "+" or "-". The vertical bar graph at the bottom of the display indicates which of the four current output steps is being used. If the transmitter can supply the requested current, the bar will turn black. If the bar does not turn black, improving the ground connections or wetting the ground where the earth stake is positioned, may help. However, it may not be able to achieve the current setting requested because the impedance of the line is too high for this setting. If this happens it is best to select a setting that has a black bar, this will ensure a stable output.

The current being transmitted will be limited by the impedance of the cable, therefore it is not unusual to increase the output level, but see no increase in the current displayed. This is not a fault with the transmitter.

The transmitter will always revert to first level output when switched on – this is a power saving feature – in most circumstances this output level is sufficient. Increasing the output power unnecessarily will reduce the battery life unnecessarily. All other settings remain the same as the last setting used.

### 5.2.6 Most Used Frequencies (Frequency Selection) Feature

This feature can be used to allow operator to choose his most used frequencies from a list of possible frequencies. Once these frequencies are selected in the main menu, pressing the "f" pushbutton, user can scroll through them. At any time user can add or remove frequencies from the above list, following the below procedure.

The advantage of this feature is that user can optimize the transmitter and activate at the main menu user's preferred frequencies, instead of having a whole list of frequencies that user has to scroll through.

To enter the "Frequency Menu" proceeds as follows:

1. Press the "i" pushbutton 5 times to get to the "Frequency selection" sub-menu.

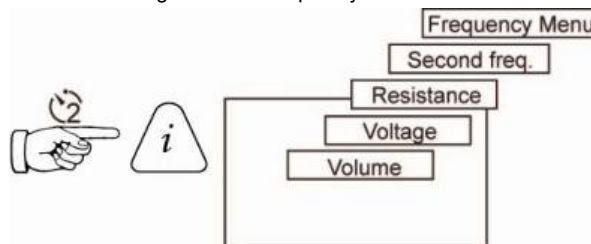

## 5 Loc-10Tx Transmitter

- Screen will show a list of frequencies available, with the central one in a box.

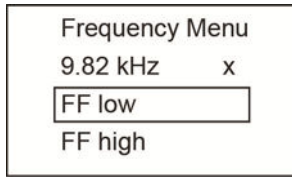

- Pressing the "+" or "-" pushbuttons, you can scroll up or down through the available frequencies.
- Once the wanted frequency is inside the box, press "f" pushbutton to select or deselect the frequency. An "x" will appear in the box for a selected frequency.

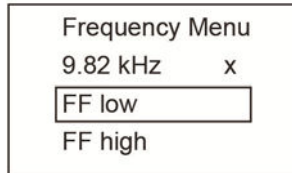

- After selecting for the frequencies, press the "i" pushbutton again to exit the "Frequency Menu" and the selected list of frequencies can be select from the main display screen. Save and exit will automatically happen if there is no pushbutton press for about 5 sec while in the "Frequency Menu".

### 5.2.7 "Dual frequency" Mode

This feature can be used when user wants to energize on user's target two frequencies at the same time. Mainly, it can be used when user is not sure which frequency can be impressed better into the target.

#### NOTE



- When using "dual frequency" mode, total power will be split between the two activated frequencies.
- This mode of operation is available only for frequencies below 40 kHz.
- The two frequencies have to be available in the main menu.

To enter the "Choose Second Freq." menu, proceeds as follows:

- Press "f" pushbutton to select the lowest frequency that user want to have in the dual combination.
- Press "i" pushbutton 4 times to get to the "Choose Second Freq." sub-menu. The above frequency will be shown in a box.

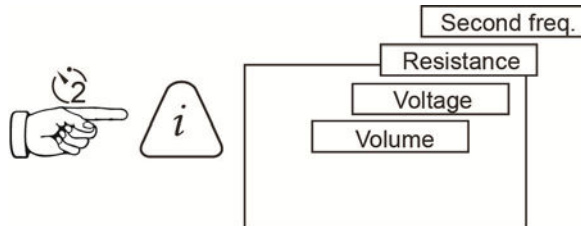

- By using the "+" and "-" pushbuttons, user can scroll through the available frequencies and bring the wanted one in the box.

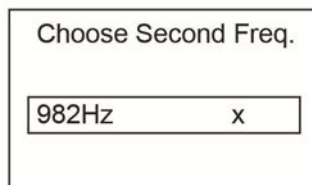

## 5 Loc-10Tx Transmitter

- Press "f" pushbutton to select the second frequency and exit the submenu to return to the main display.
- In the main display screen, both frequencies are displayed. The frequency will toggle between the two chosen frequencies.



### NOTE

If user is changing the selected frequency by pressing the "f" pushbutton, this mode will be deactivated. To reactivate it, user has to follow again the above procedures.

If the unit is powered down, this mode will be reset. To activate it again after power up, user has to follow the above procedures.

### 5.3 Information

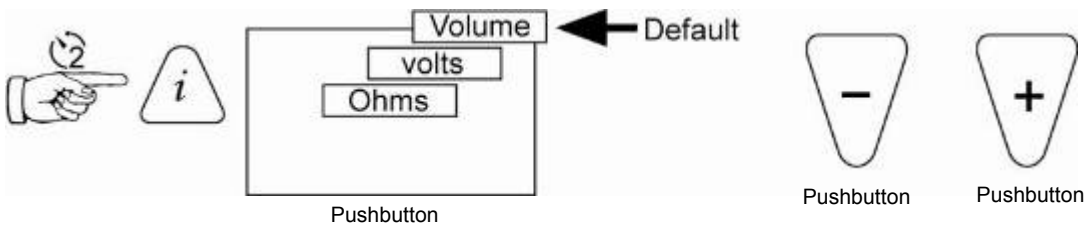

The digits in the center of the display default to output current (in mA).

When the "i" (information) pushbutton is pressed, the display will show the volume level of the audio; use the "+" and "-" pushbuttons to increase/reduce the volume or turn the beeper off (off – low – medium – high).

By pressing the "i" (information) pushbutton the display can be toggled to show "voltage" and "resistance". The display indicates mA, as the default, and volts or ohms when selected.



# Loc-5Tx Transmitter

## 6.1 Pushbutton

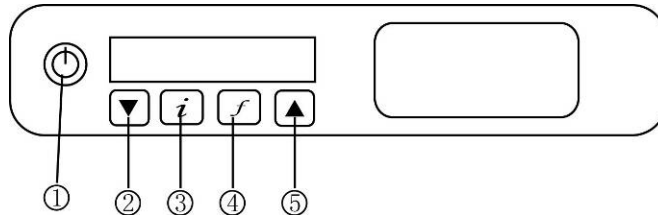

1	On/Off Control
2	Output Decrease
3	Information (Volume, mA, Volts, Ohms)
4	Frequency Select
5	Output Increase

## 6.2 External Connectors

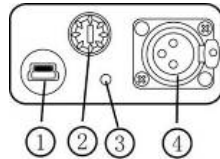

1	Mini USB Port
2	Output Fuse
3	Speaker
4	Output Connection

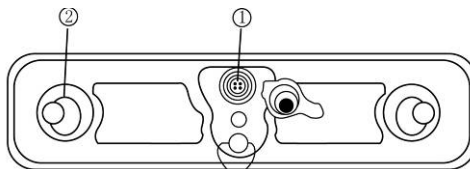

1	Battery Charging Socket & DC Input
2	¼ turn fasteners

## 6.3 Transmitter Battery

In most markets the transmitter is shipped with alkaline batteries (8 x D cells) unless rechargeable batteries are specified. Batteries are fitted into quick release trays – the alkaline is an open pack, to enable the batteries to be changed. The rechargeable pack is a sealed unit containing Ni-MH (Nickel Metal Hydride) batteries. These packs can only be fitted in a manner to ensure that the alkaline batteries cannot be inadvertently charged.

### 6.3.1 Removing the Battery Tray

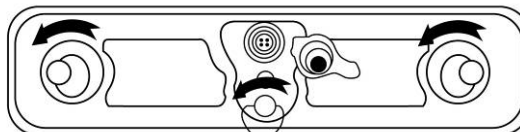

To remove the tray operate the three ¼ turn fasteners in an anti clockwise direction. This should now release the tray which can then be slid out from the transmitter body. Be careful not to allow the batteries to fall from the tray as it is removed from the body.

### 6.3.2 Replacing Alkaline Batteries

- Replace with new batteries of the same type, be sure not to mix old and new batteries.
- Do NOT use rechargeable batteries in the alkaline battery tray. Ensure that batteries are inserted the correct way (see label “+” and “-” on the side of the tray).
- Refit the battery tray and operate the three ¼ turn fasteners in a clock wise direction.

**WARNING**

**Alkaline Batteries – insert alkaline batteries (x8) as shown**



### 6.3.3 Rechargeable Batteries

- Do NOT attempt to replace the rechargeable batteries or remove battery covers – return to Vivax-Metrotech or a Vivax-Metrotech approved service centers for replacement.



**WARNING**

**Use only Vivax-Metrotech recommended charger.**

### 6.3.4 Re-fitting the Battery Tray

Refit the battery tray and operate the three ¼ turn fasteners in a clock wise direction.



**WARNING**

**Power “IN” socket**



**Two pins are used for power in from charger (to charge rechargeable batteries).  
Two pins are used for power from external 12V DC source. (e.g. 12V DC  
cigarette lighter supply from automobile)**



**NOTE**

**Rechargeable pack cannot be charged from a 12V DC source.**

Contact Vivax-Metrotech or a Vivax-Metrotech approved service center for wiring diagram of plug, if attempting to repair any of the “charging” leads.

### 6.3.5 Battery Charging and Disposal

Follow instructions detailed in the General Safety & Care portion of this document.

Only use the charger supplied with the equipment. Using a non approved battery charger may damage the batteries and cause overheating.

The charger is mains operated. Connect the charger to the battery pack at the rear of the transmitter. Switch on the charger. The LED on the charger will show a red light indicating that the charge process has started. When the LED changes to a green indicator the charge sequence is complete and the batteries will be fully charged.

### 6.3.6 Battery Condition Indication

The battery condition (charge) is displayed on the left side of the display, in the case of the rechargeable batteries the condition is also indicated on the charger (red/green light).

## 6.4 Display

- Start up screen, software configuration



- Main screen



1	Frequency Being Transmitted
2	Battery Status
3	Signal Current Out (mA)
4	Mode Indication

- Clamp Mode



- Induction Mode



- DC Measurement



If a DC measurement is required, while in the voltage and resistance screen, press and hold the “i” pushbutton. The unit will enter in to the DC measurement sequence and at the end of it will display the DC resistance of the load.

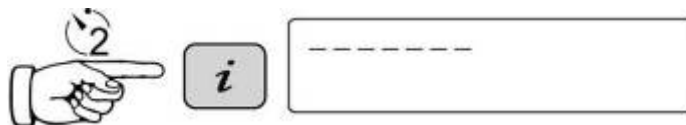

Screen showing DC resistance of the load.

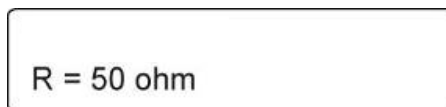

### 6.5 Multi Frequencies

To transmit simultaneous up to 3 frequencies proceed as follows:

1. Place the transmitter in the first frequency using the "f" key in the main menu
2. Press the "i" key 3 times. The display will show the screen below with "Freq # 2" and "Freq # 3" flashing. This mean they are not set yet.



3. At this point, with the "up" and "down" keys you can select the second frequency to be transmitted. Once in the proper selection, press the "f" pushbutton to confirm. The "Freq # 2" row will not flash any more confirming that it has been set. Repeat the above procedure for the third selection or press "i" to exit this menu, if a third frequency is not needed.
4. Main display will show the "MULTI" as a mode of operation as shown below.



**NOTE**

The "MULTI" mode is only a one time mode. If the unit powered down the MULTI mode has to be reactivated.

### 6.6 Most Used Frequencies (Frequency Selection) Feature

This feature can be used to allow operator to activate the most used frequencies from a list of possible frequencies. Once these frequencies are selected in the main menu, pressing the "f" key, scrolls through them. At any time the user can add or remove frequencies from the above list, following the below procedure.

**Procedure:**

To enter the "Frequency Menu" you can proceed as follows:

1. Press the "i" pushbutton 3 times to get to the "Frequency selection" sub-menu.

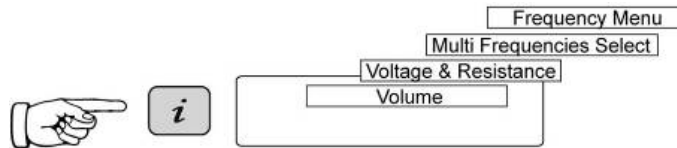

Screen will show the available frequencies.

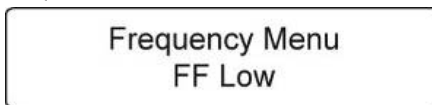

2. Pressing the "+" or "-" pushbuttons, you can scroll up or down through the available frequencies.
3. Once the wanted frequency is shown on screen, press "f" pushbutton to select or deselect the frequency. An "√" will appear in the box for a selected frequency.

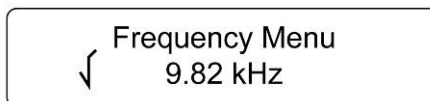

After selecting for the frequencies, press the "i" pushbutton again to exit the "Frequency Menu" and the selected list of frequencies can be select from the main display screen. Save and exit will automatically happen if there is no button press for about 5 sec while in the "Frequency Menu".

### 6.7 Induction Mode

This uses an internal antenna to induce a locating frequency onto the target pipe or cable (Line). "Induction" mode is automatically selected if no connection accessories are plugged into the "output socket". In order to generate successful induction, the transmitter should be positioned over and in line with the target line.

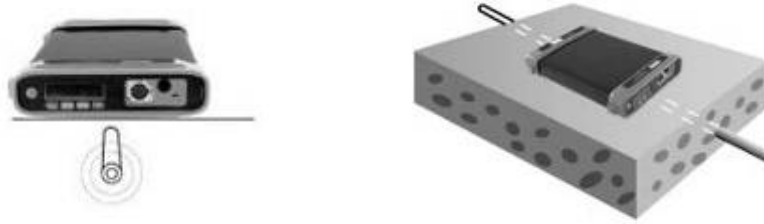

"Induction" mode is generally used when no access is available to make a direct connection, or a clamp connection. When using induction it is very likely that the signal being induced onto the target line will also be induced onto other lines in the area, and onto above ground features such as wire fences. This can influence the accuracy of the location, depth and current measurements. "Induction" mode is also the least efficient way of applying the transmitting signal to the target line. The distance located with "Induction" mode is generally much less than that achieved with a direct connection or clamp connection. "Induction" mode generally works better in higher frequencies, 33 kHz, 65 kHz and either 83.1 kHz (depending on region). The advantage of induction is that no access is required to "connect" the transmitter, making it a very quick process. The antennas on the transmitter are tuned to induce specific frequencies or range of frequencies. Therefore only a limited number of frequencies can be selected in "Induction" mode.



**NOTE**

**For accurate location and depth measurement the locator receiver should not be used within 50ft/(20m) meters from the transmitter.**

### 6.8 Direct Connection Mode

A connection lead set is supplied with the Loc-5Tx transmitter. This lead set is used to make an electrical connection to a cable or pipe that is to be traced. One of the leads is connected to the line and the other to a ground point that is nearby or a by inserting the ground rod supplied with the equipment and connecting to that.

A good connection is indicated by a change in tone from the speaker and a current reading on the display.

More information can be found in section 5.2.2

### 6.9 Clamp Mode

The signal clamp is an optional extra. There are three different sizes 2in (50mm), 4in (100mm), 5in (125mm), 18in flexible (450mm).

The clamp is generally used to apply the signal tone to a live cable or telecom cable where an electrical connection is not possible because of safety or access issues.

Please refer to section 5.2.3 for further information.



# Loc-1Tx Transmitter

## 7.1 Pushbutton

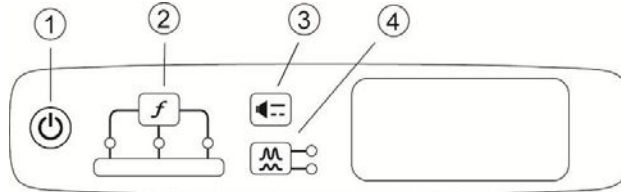

1	On/Off Control
2	Frequency Select
3	Pulse/Continuous setting
4	Output High/Low setting

## 7.2 External Connectors

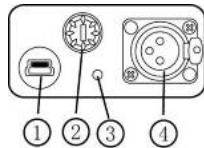

1	Mini USB Port
2	Output Fuse
3	Speaker
4	Output Connection

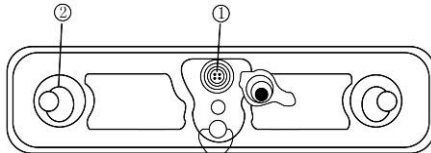

1	DC Input
2	1/4 turn fasteners

## 7.3 Replacing Alkaline Batteries

- Replace with new batteries of the same type, be sure not to mix old and new batteries
- Do NOT use rechargeable batteries in the alkaline battery tray. Ensure that batteries are inserted the correct way (see label “+” and “-” on the side of the tray)
- Refit the battery tray and operate the three 1/4 turn fasteners in a clock wise direction

### WARNING

**Alkaline Batteries – insert alkaline batteries (x4) as shown**



## 7.4 Rechargeable Batteries

Rechargeable batteries are not available for the Loc-1Tx transmitter.

## 7.5 Loc-1Tx Transmitter Operation

The operation of the Loc-1Tx transmitter is very similar to the Loc-5Tx transmitter. This is covered in section 6.7 to 6.9.

## Using the vLoc-9800

### 8.1 Using the Receiver

#### 8.1.1 Line Locating

Line locating is a term used to describe the action of locating the position of a pipe or cable. When line locating, the receiver should be held with the display forward, and then swept to the left and right, across the suspected direction of the buried line. The largest signal will be detected when directly over the line. If the direction of the line is known it should be possible to trace the route using the Left Right Auto mode. If in doubt, switch to the manual mode to confirm the position and direction. The Auto and Manual modes are explained in more detail in Section 3.

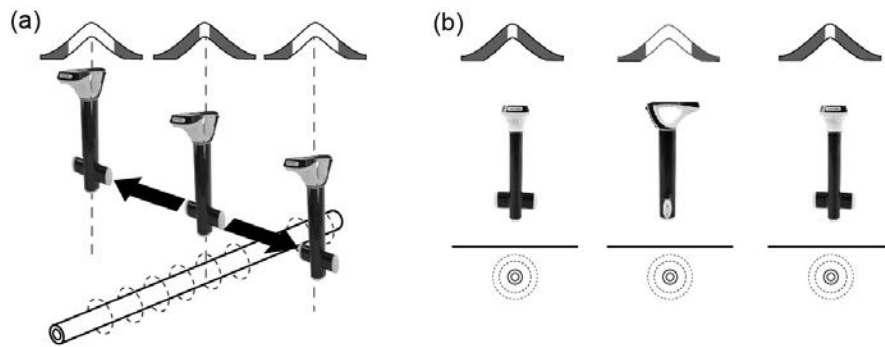

The receiver should be kept parallel to the ground – and should not be flipped up at the end of each pass. See diagram (a).

To establish the direction of the cable – use the “M” pushbutton to select the Manual mode. Pinpoint the line – by carefully establishing the exact “Peak” position. Then (with the base of the receiver on the ground) rotate the receiver through 90 degrees, as you do this the signal being received will reduce substantially (possibly disappear). Then rotate the locator until you find the maximum “Peak”. The front of the locator is again facing in the direction of the buried line. See diagram (b).

#### 8.1.2 Depth & Current Measurement

Pinpoint the exact position of the cables as above:

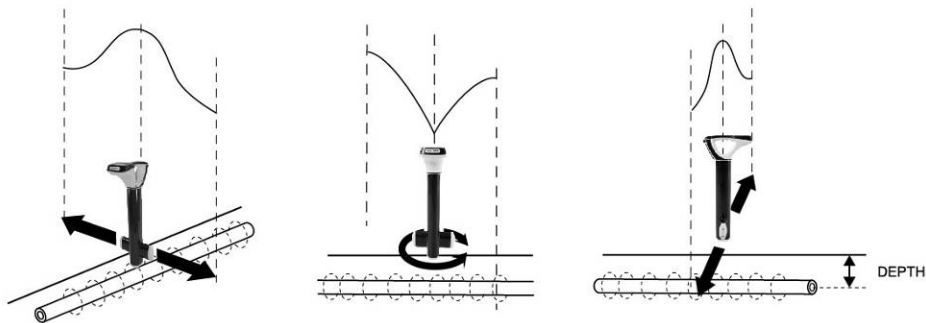

Once the position and direction of the cable has been established, stand with the base of the locator on the ground – with the locator in the absolute “Peak” position (over and in line). Then press the “i” information pushbutton briefly, the current and depth will be displayed.

### 8.1.3 Sonde Location

This is used for locating a Sonde only. A Sonde is a transmitting coil and the signal radiates in a different manner than that of a line (see diagram b).

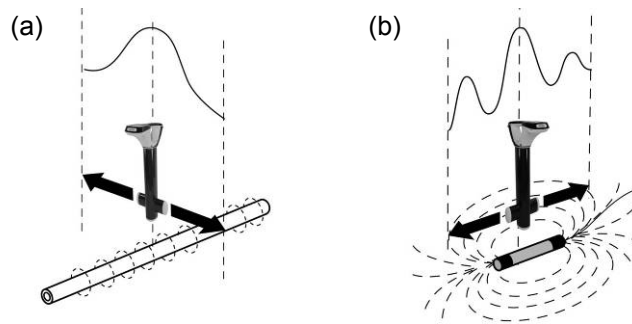

Note that there are 3 distinct peaks: a small peak, a large peak, a small peak. The Sonde is located under the center of the "large peak". When locating across the direction of the Sonde it provides the conventional peak response.

A Sonde is typically used for locating non metallic pipes or ducts, and the camera end of a sewer inspection camera. Low frequency versions (512Hz/640Hz) can transmit through some metallic pipes such as cast iron pipes – which is why they are frequently used with sewer inspection cameras.

Ensure Sonde mode is selected as depth measurements taken from a Sonde in any mode other than Sonde mode will be inaccurate.

## 8.2 Passive or Active Location

There are two types of location method available with this system, they are:

### 8.2.1 Passive Locating

Passive locating of buried utilities uses electromagnetic signals that exist in the environment. We group these under two settings:

- Power (P) – these are signals that generally originate from electrical power generation systems. These are around 50/60Hz and their associated harmonics.
- Radio (R) – these are signals that generally originate from low frequency radio transmissions. These are generally in the range of 16 kHz to 22 kHz.

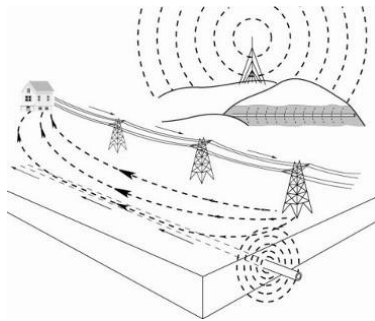

Passive location is used to search an area to see if buried metallic lines are present (known as locating to AVOID). It does not help to identify what buried pipe or cable is present, only to confirm that there is a pipe or cable there. A typical application would be to check an area before installing a fence post.



**NOTE**  
Passive locating can only be done in the manual mode.



### 8.2.2 Active Locating

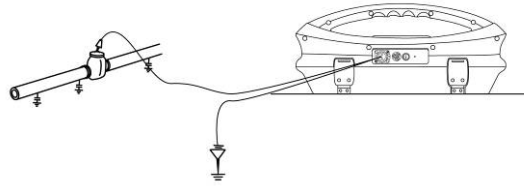

Active locating is using a transmitter to apply a very precise frequency to a pipe or cable, and then using a receiver turned to find the signal being radiated at that precise frequency. Active location frequencies can be applied by direct connection, clamp or induction.

This transmitter operates at a range of frequencies for active location.

The choice of frequencies when using induction or the clamp is restricted due to the requirement that these modes be tuned for specific frequencies (or range of frequencies). The full range of frequencies is available in "Direct connection" mode.

For frequencies below 45 kHz, authorities such as the FCC allow higher power output to be used; for frequencies of 45 kHz and above, power output for this type of equipment is restricted to 1 watt. Therefore more power is available when lower frequencies are used.

### 8.3 Applying the Transmitter's Signal

The transmitter's signal cable is applied in any one of the three ways:

#### 8.3.1 Direct Connection

This is used on pipes or cables that are not live and do NOT carry hazardous voltages. The "Direct connection" mode will be selected automatically when the connection leads are plugged into the transmitter.

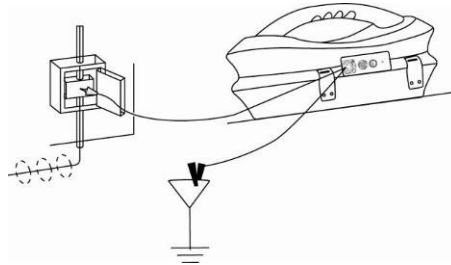

#### WARNING

**Never make a direct connection to live cables carrying hazardous voltages.**

Do NOT plug the connection leads into the transmitter before connecting to the buried line and fixing the ground stake.

Take the ground stake and push firmly into the ground and connect it to the black connection lead.

To make the signal travel further along the buried line, ensure to place the ground stake as far away as possible, and at 90 degrees to the line. Where practical avoid having other buried lines between the ground stake and the target line, this will reduce the chances of the transmitter signal coupling to another pipe or cable.

Do NOT connect the black lead to any other metallic items that may have an above or below ground structure, or to any other pipes or cables; connecting to such items would cause signals to radiate from these secondary structures, which in turn will increase the likelihood of an incorrect locate.

Connect the red connection lead to the target line after removing any surface corrosion.

Plug the connection leads into the transmitter switch on and select the desired frequency.



**WARNING**

**BE CAREFUL not to hit other buried lines when inserting the ground stake into the ground. Check using passive location prior to inserting ground stake. Stop if additional resistance is felt during insertion.**

**8.3.2 Clamp (Coupler)**

This is used when applying the transmitter signal to cables carrying hazardous voltages, or cables where access to the metallic conductor is not possible, or desirable. The "Clamp" mode is selected automatically when the clamp is plugged into the transmitter.

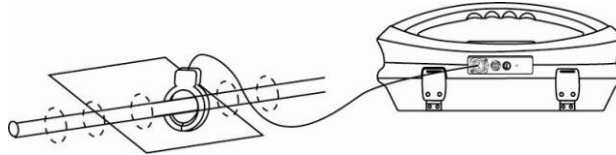

For a clamp to work the current induced by the clamp must flow along the buried line. This means the buried line must have a ground connection at both ends.

Do NOT plug the clamp into the transmitter before applying it to the target line. Open the jaws of the clamp, place around the target line, close the jaws. Be sure that the jaws of the clamp are completely closed. After applying the clamp, plug it into the transmitter, switch on and select the required frequency. Clamps are generally turned to specific frequencies. Your transmitter only allows frequencies that are compatible with the clamp to be selected.

Please note – at the end of the clamp, and in the area close to the clamps hinge the exposed end of the clamp laminations can be seen. Any dirt or corrosion on these ends will reduce the efficiency of the clamp.



**WARNING**

**ALWAYS follow the appropriate safety requirements mandated by safety legislation, safety practice or your company's safety procedures when applying a clamp (coupler) to a cable.**

**BEWARE that when placing a clamp around cables carrying high current, the clamp may vibrate, jump or close violently due to inducted current from the target cable.**

**8.3.3 Induction**

This is used when no connection via direct connection leads, or coupler is possible. If no connection leads or clamp are connected to the transmitter, it will automatically select "Induction" mode.

An induction loop is fitted inside the handle of the transmitter. The transmitter must be placed over the target cable with the handle over and in line with the target pipe or cable. The induction loop is tuned to operate at specific frequencies. Only these frequencies can be selected when in "Induction" mode.

Do NOT place the transmitter on a manhole cover, or any other such metallic object, as that object will shield or soak up the signal resulting in little or no signal being induced in the target line.

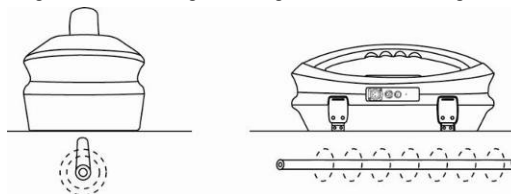

## 8 Using the vLoc-9800

When using the "Induction" mode to apply a signal to a line, ensure that a minimum distance of 50ft (20m) is maintained. This is because the transmitter will transmit signal through the air which will interfere with signals from the cable, resulting in incorrect information.

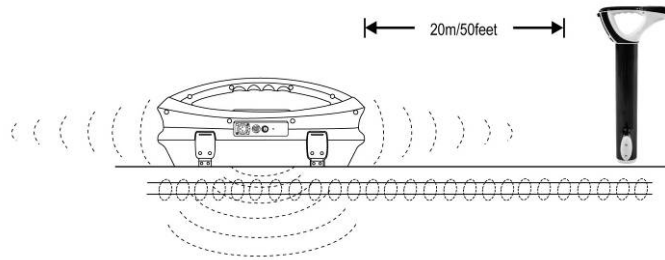

### 8.3.4 Searching (sweeping) an Area

In any given area, it is likely that buried pipes and cables are not parallel to each other, frequently they will cross the area being searched at a variety of different angles and depths. As the response of locator antennas is directional, it is important to search the area in the same or similar pattern as below. This orients the antennas in a way that will locate any signals being radiate from the buried line. Once a response is found, then trace and pinpoint the line and mark. Searching an area in this way is generally (but not exclusively) done in the "Peak" mode using passive locating.

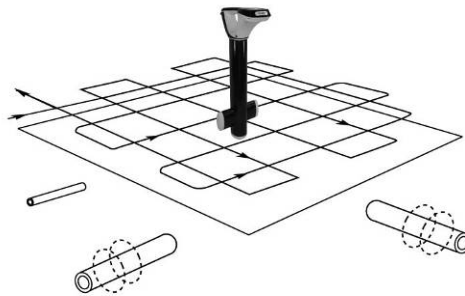

### 8.3.5 Tracing a Buried Line

Once a buried line is located it is generally necessary, and a good practice, to trace that line for some distance in both directions. Whenever practical it should be traced to a point that provides additional confirmation of what type of service is being located (a telephone pedestal, a manhole cover etc). If tracing a line to which a transmitter signal has been applied, one should trace out from the transmitter connection point. The receiver should be held level to the ground and rotated in a small arc across the anticipated route of the buried line. A clear response should be visible on the display and heard audibly.

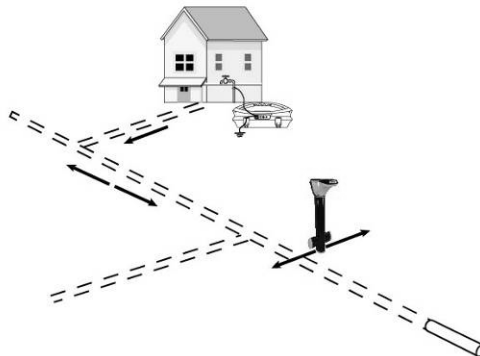

### 8.3.6 Pinpointing & Confirming the Buried Line

Marking the exact position of the buried line is generally called pinpointing. Pinpoint the line before marking its position. Place the receiver in "Peak" or "Left/Right" mode, pass the blade of the receiver across path of the cable and identify the peak response on the display and/or audibly.

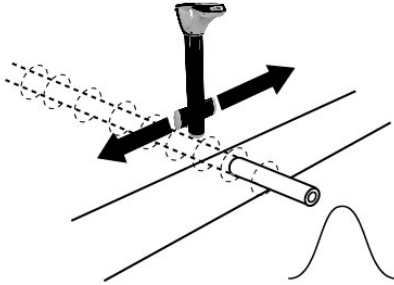

### 8.3.7 Distorted Fields

When locating always be aware that you are locating the signals radiating from the buried line, and these radiated fields as they are called can be distorted by other lines or electromagnetic buried lines or metallic features like crash barriers or wire mesh fences. The risk of an inaccurate location can be reduced further by the following:

- To check if the signal is being distorted by other radiated fields. First locate the cable in the either mode. Place the locator on the ground and take a depth reading by pressing the "i" pushbutton. Note the result and then raise the locator approximately 1.5ft (0.5m) Take another depth reading and check the depth has increased by this amount. If it has, the depth is likely to be correct. If it has not, then the depth is not likely to be correct because the signal is distorted.

### 8.3.8 Measuring Depth and Current

- Pinpoint the cable as described in "Pinpointing cable", with the receiver in line with and directly above the buried line – measure the depth (d) by pressing "i" pushbutton briefly. Current will be displayed at the same time as the depth.
- Be careful when locating in congested areas or close to bends or tee's, they may be inaccurate due to distorted fields.

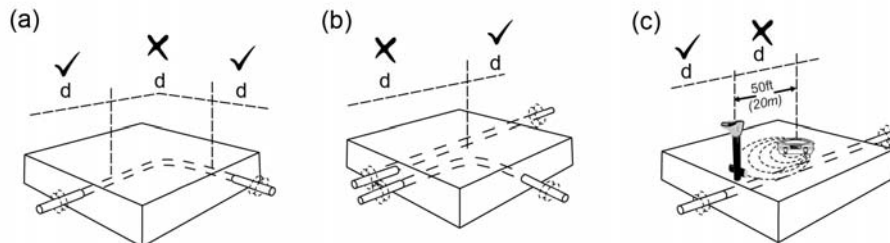

- An alternate method of verifying depth (D) is triangulation which can be done in the "Peak" modes

A) Peak Mode(Twin Antenna)

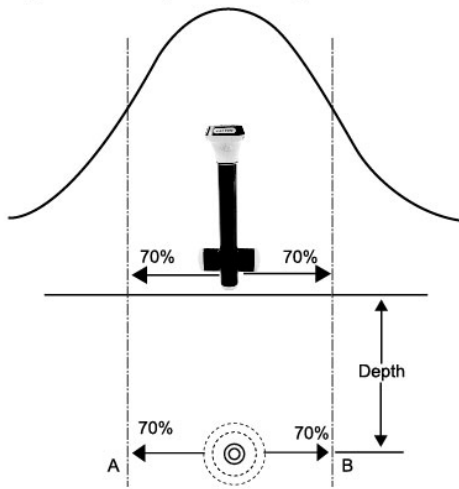

Distance A to B = Depth (D)

B) Broad Peak Mode(Single Antenna)

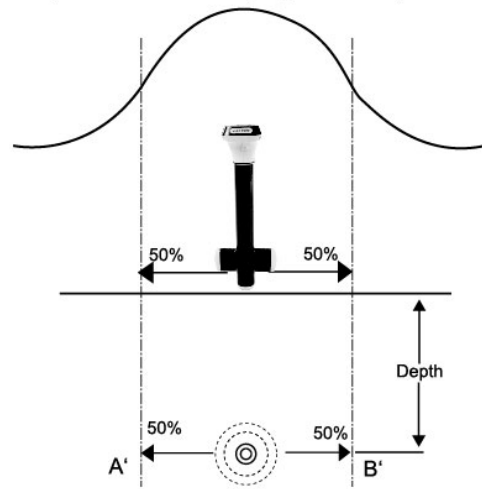

Distance (A' to B')/2 = Depth (D)

- Measuring the signal current. Pinpoint the line as for measuring depth. The current can be displayed by briefly pressing the "i" pushbutton. Depth and current will be displayed the signal from the transmitter will attenuate with distance. The further from the transmitter the less signal will radiate from the buried line. By locating at several points along the buried line you will identify an approximate rate of signal loss (beware that where a pipe or cable divides the signal will reduce more rapidly). If the signal current at the point you are pinpointing is different from the trend would suggest, check to confirm that the correct cable is being located. To do this return to a point where the current is as expected and very carefully trace the line to the new location checking regularly that the current has not changed significantly. A sudden change in current may be caused by straying onto an adjacent line.



**WARNING**  
NEVER mechanically dig over the path of a buried pipe or cable. ALWAYS dig carefully.

## 8.4 Using the Accessories

### 8.4.1 Using the LPC Separation Filter



The LPC separation filter (LPC) is used to safely inject a trace tone to a live cable via a domestic mains socket, so that the cable can be traced from the premises to the connection in the street. It is suitable for connecting to voltages between 100V AC and 250V AC.

**Method:**

Plug the LPC into the output socket of the transmitter. Identify a suitable main socket. If a switch is fitted to the socket, switch off. Plug in the LPC to the mains socket and then switch back on. Set the LPC rotary switch to match the two indicator lights. Set the transmitter to the frequency to be located.(8 kHz or 32 kHz are good frequencies for this application). Set the output to mid range.

### 8.4.2 Using the A-frame in Fault Finding



The A-frame accessory is used to detect ground faults on pipes and cables. In the case of pipes, the faults consist of coating defects. In the case of cables, faults are usually caused by insulation damage allowing the metallic sheath (or internal conductor) to become in contact with the ground.

To detect a damaged section, the line should be isolated and have all ground bonding removed. This will ensure that the ground fault is not masked by deliberate bonding to ground. The A-frame cannot distinguish between these two situations.

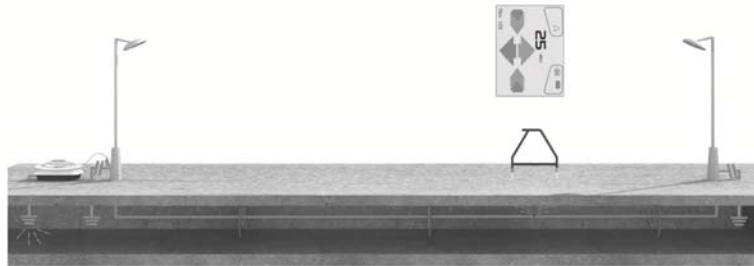

After isolating the line, use the vLoc-9800 transmitter resistance measuring function, or a dedicated resistance measuring device to confirm that there is a fault to ground. The A-frame will typically detect faults up to 2 mega ohm and above (depending on the distance from transmitter, soil conditions etc).

Connect the transmitter to the target line using the red lead. A ground stake needs to be pushed into the ground and the black cable clipped to it. Try to place the earth stake as far as possible from the line to be evaluated. This ensures return currents do NOT distort the results. Switch on the transmitter and select either FF low or FF high. Use FF high if the line to be surveyed is long or the fault resistance is high.

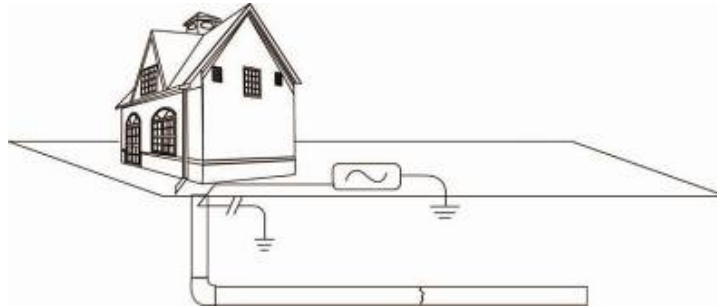

Plug in the A-frame to the receiver accessory socket. When the receiver is switched on, it will automatically default to the A-frame screen.

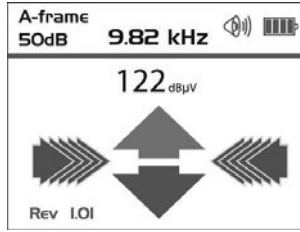

Remove the plastic spike Image for reference only and may differ from actual image ing the spikes of the A-frame in the ground (with the green leg pointing away from the transmitter connection point) every two or three paces. If starting near the transmitter, the Arrow on the display will point away from the ground point. As the distance from the transmitter increases, the dBuV reading will reduce and eventually the arrow will fluctuate or disappear all together. This is because the fault location is further along the line. If the left/right arrows are activated, use them to ensure the A-frame is positioned over the line and continue placing the A-frame in the ground every two or three paces. If the left/right arrows are not activated use the "M" pushbutton to enter the locate screen allowing the user to confirm the position of the target line. Press the "M" pushbutton again to re enter the A-frame mode.

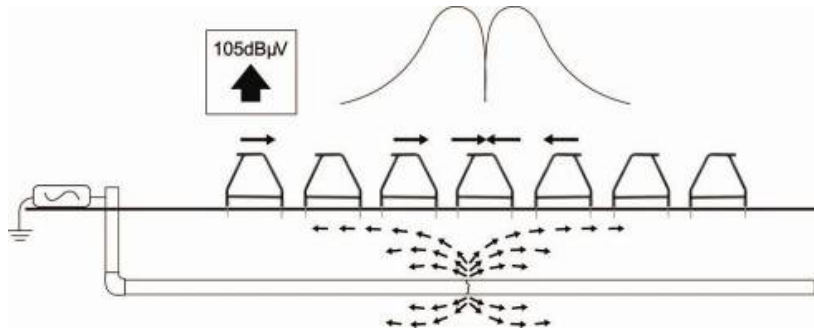

Eventually the A-frame will detect the fault signal and the "Fault Find" arrow will point forwards. Continue moving forwards, it may be worth reducing the distance between measurements points as the fault is neared. The dBuV reading will increase as the fault is neared. Maximum reading will be just before and just after the fault. When over the fault, the dBuV reading will drop and the arrow will flip backwards indicating that the position of the fault has been passed. Carefully place the A-frame before and after the fault to pinpoint the position. Repeating this across the line direction will pinpoint the fault laterally. The fault will be at the point where the lateral fault is identified.

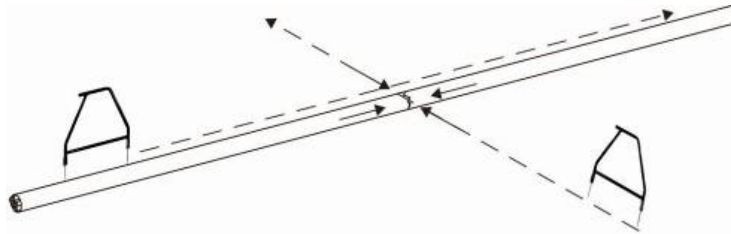

**WARNING**

Always disconnect or isolate cables before making connections to conductors. Never attach the transmitter to live cables unless authorised. Use the appropriate accessories.



**TIP**

If it is suspected that there is just one fault. Insert the A-frame approximately one meter from the earth stake. Note the dBuV, this is approximately the maximum dBuV reading that will be measured over the fault.

### 8.4.3 Using the Remote Antenna USB



The remote stethoscope antenna can be used to help identify a particular cable on a cable tray or where cables are bunched together.

#### Methods:

1. Connect a signal to the cable to be identified. The remote stethoscope functions has an operational frequency range of 512Hz up to 200 kHz, but low frequencies should be a preference in this application as they are less likely to leak or bleed over to other cables.
2. The best method of signal application when identifying cables is to use the signal clamp. This is because the signal clamp applies a signal to the target cable and shares an equal amount with other cross bonded cables.

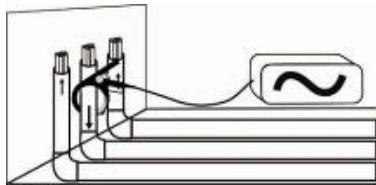

3. When using the signal clamp, both ends of the target cable should be grounded. Apply the clamp below the ground point. Applying the clamp above the ground point will prevent the signal finding the return path through the ground, so is not advised.

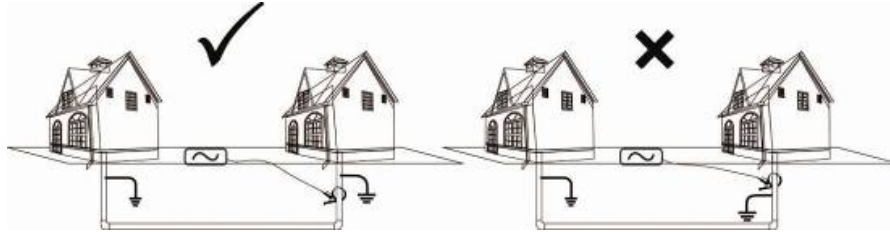

4. If this is not possible use a transmitter signal clamp and you have confirmation that the cable is out of service, use a direct connection lead to make an electrical connection to the cable. Removing any cross bonding between cables prevents the signal travelling along commonly bonded cables.

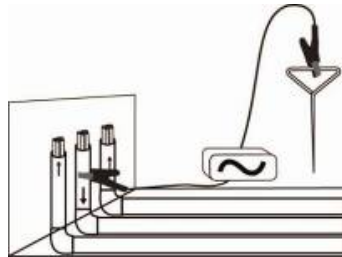

5. Do NOT use the Induction method as the signal will appear on all cables in the area of the transmitter.
6. Connect the remote stethoscope antenna to the accessory input of the Receiver. The correct settings and user interface will be automatically selected.



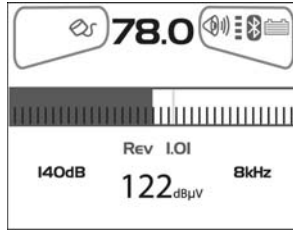

7. Ensure the frequency selected on the vLoc is the same as selected on the transmitter.
8. Place the stethoscope on each of the suspected target cables with the flats of the antenna in line with the route of the cable.

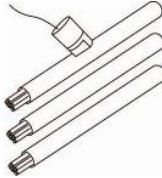

9. Note the dB reading of each cable. The one with the largest reading is likely to be the target cable.
10. If necessary adjust the sensitivity of the vLoc so that the signal is within the operating section of the bar graph. This will help identify the cable if the signal levels are similar because of cross coupling of the signal.



**WARNING**

The remote stethoscope antenna is a useful tool to help identify cables. However, it should not be used as positive identification before an unused cable is cut. Always follow company procedures when cutting disused or isolated cables.



**TIP**

The remote antenna USB stethoscope can be used to help identify disused and isolated cables. This process can be further enhanced if the cable is isolated and is of a twisted cable construction.

**Method:**

1. Connect the transmitter to two of the cores of the cable. At the far end short together these two conductors making a loop.
2. Set the transmitter to a low frequency such as 640Hz and set the output to maximum.

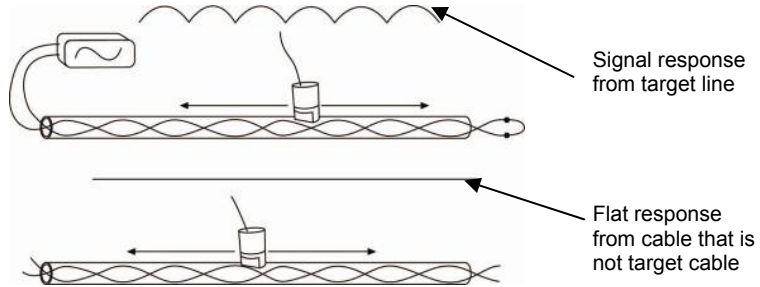

3. At the point of interest, run the remote stethoscope antenna along the suspected target cable. If the correct cable is being assessed the signal will increase and decrease in sympathy with the twist of the two conductors within the cable.
4. If the signal is a steady level and does not rise and fall, this is probably NOT the target cable.



**WARNING**

The remote stethoscope antenna is a useful tool to help identify cables. However, it should not be used as positive identification before an unused cable is cut. Always follow company procedures when cutting disused or isolated cables.

## Accessories & Options

### 9.1 A-frame (Optional)



The A-frame accessory is used to detect ground faults on pipes and cables. In the case of pipes, the faults consist of coating defects. In the case of cables, faults are usually caused by insulation damage allowing the metallic sheath (or internal conductor) to become in contact with the ground.

### 9.2 Remote Antenna (Optional)



The remote antenna can be used to help identify a particular cable on a cable tray or where cables are bunched together.

### 9.3 Loc-10Tx Vehicle Power Lead (Optional)

12V DC, 30ft (10m) lead to power the transmitter from a vehicle.

Note, this is NOT a charge lead.



If it is intended to apply the transmitter to a target line at high output levels and long periods, it may be useful to power the transmitter using the 12V DC vehicle power lead. To power the transmitter from the 12V DC vehicle power lead, connect the lead to the 12V DC input positioned on the side of the transmitter. Plug the cigarette lighter plug into the vehicle cigarette lighter socket (be sure that the socket is live. Some vehicles only activate the cigarette lighter when the vehicle is running).

It is not necessary to disconnect or remove the standard batteries as the unit will automatically select the external 12V DC supply.

### 9.4 Loc-10Tx Outdoor Power Supply (Optional)



12V DC, 30ft (10m) lead to power (NOT charge lead) the transmitter from the mains supply.

Note, this is NOT a charge lead.

### 9.5 LPC Separation Filter (Optional)



The LPC separation filter (LPC) is used to safely inject a trace tone to a live cable via a domestic mains socket, so that the cable can be traced from the premises to the connection in the street. It is suitable for connecting to voltages between 100V AC and 250V AC.

### 9.6 Receiver Vehicle Charging Lead (Optional)



12ft (4m) long lead to charge the receiver's battery (Lithium-ion) while on the move.

It is preferable to connect the charger to a cigarette lighter socket that is permanently live. However, do NOT leave connected to the receiver for excessively long periods.

### 9.7 Sonde (Optional)



#### D38-33-AA Sonde

- 1.5in (38mm) x 4.1in (105mm) long, 33 kHz, range 16.3ft (5m).
- 1 x AA battery.

#### D38-09-AA Sonde

- 1.5in (38mm) x 4.1in (105mm) long, 9.8 kHz, range 16.3ft (5m).
- 1 x AA battery.



#### D64-33-LR61 Sonde

- 2.5in (64mm) x 7.3in (186mm) long, 33 kHz, range 26ft (8m).
- 1 x LR61 battery.

#### D64-09-LR61 Sonde

- 2.5in (64mm) x 7.3in (186mm) long, 9.8 kHz, range 26ft (8m).
- 1 x LR61 battery.

### 9.8 Clamp (Optional)



- VX2/50, VX4/100, VX5/125, VX18/450F
- Dia. 2in (50mm), Dia. 5in (125mm), Dia. 4in (100mm), 18in flexible (Circumference 450mm)

An accessory used to apply the transmitter signal to an insulated line, removing the need to connect the transmitter signal directly to a conductor or cable sheath.

### 9.9 Lithium-ion Rechargeable Battery Pack (Standard)



The Lithium-ion rechargeable battery pack is supplied as standard. Use the battery charger listed below to charge the battery pack. Charging is done with the battery inside the receiver.

### 9.10 Receiver Battery Charger (Standard)



The receiver Lithium-ion battery charger is supplied as a standard item. It is powered from the mains supply (100-250V AC)

### 9.11 USB Cable (Standard)



The USB cable is used to connect the receiver to a host computer so that software updates can be implemented and also for the transfer of data logs from the unit to a computer.

### 9.12 Alkaline Battery Holder (Standard)



This battery pack is supplied as standard and is used in the event the rechargeable battery pack has fully discharged. It can be considered as a backup battery pack. It requires 6 x AA alkaline batteries.

### 9.13 Ground Stake (Standard)



Used to make an independent connection to the ground so as to complete the circuit when the transmitter is connected to a line using the direct connection method.

### 9.14 Direct Connection Lead (Standard)



Used to connect the transmitter to a line using the direct connection method.

### 9.15 Loc-1Tx Alkaline Battery Tray (Standard)



Requires 4 x Alkaline D cells.

### 9.16 Ground Spool (Optional)



Used to extend the ground connection to a suitable grounding position.

### 9.17 *Banana Plugs Adapter (Optional)*



Adapts the direct connection crocodile clip to banana plug allowing the direct connection leads to be connected to a banana socket.

### 9.18 *Loc-5Tx Battery Pack (NiMH)*



NiMH rechargeable battery pack. Only use the charger supplied as below.

### 9.19 *Loc-5Tx Alkaline Battery Tray*

Requires 8 x Alkaline D cells.



### 9.20 *Loc-5Tx/10Tx Charger*



Mains charger (100-250V AC input) used to charge 5 Watt or 10 Watt rechargeable battery packs. Supplied as standard with rechargeable battery option.

### 9.21 *Loc-10Tx Rechargeable Battery Tray*

NiMH rechargeable battery pack. Only use the charger supplied.





### 9.22 *Loc-10Tx Alkaline Battery Tray*

Requires 12 x Alkaline D cells.



# Glossary

Active Locate	A locate where a transmitter is used to apply a signal to a buried pipe or cable, the position of which is then located by a receiver tuned to the same frequency.
Active Signal	A signal applied by the locator transmitter to a buried line. Typically this is a very precise frequency.
Attenuation	The reduction of an electromagnetic signal from a pipe or cable.
Clamp (or Coupler)	An accessory used to apply the transmitter signal to an insulated line, removing the need to connect the transmitter signal directly to a conductor or cable sheath.
Compass	Line direction indicator (although visually like a compass, this is the only relation to a compass.)
Coupling	The act of signals transferring to lines to which they were not originally applied. Coupling can be "direct" where the target line has an electrical connection to another line, or "induced" where the signal radiates from the target line to another line or lines.
Display	The information visually available on the dot matrix display.
Line	A generic term for any buried pipe or cable.
Null	A minimum response to a buried line. 
Passive Locate	A locate where the receiver searches for a wide range of signals that radiate from buried pipes or cables. These signals come from a variety of sources in the environment and couple to the buried (& overhead) lines. Typical examples 50 / 60Hz and LF/VLF radio.
Passive signals	A wide range of signals that radiate from buried pipes or cables. These signals come from a variety of sources in the environment and couple to the buried (& overhead) lines. Typical examples 50/60Hz and LF/VLF radio.
Peak	A maximum response to a buried line. 
Pinpoint	Using a receiver to identify the exact position of a buried line.
Response	The indication that the receiver gives which is caused by the signals it is receiving. This can be visual, audio or both. Typically it is displayed on the locator's dot matrix display and audibly from a loudspeaker in the receiver housing.
Search (sweep)	This describes the act of looking for a buried line within a given area.
Sonde	A small transmitting coil which may be built into a product such as a sewer camera or packaged as a small self-contained battery-powered transmitter. A receiver tuned to the same frequency can locate the position of the Sonde and

## 10 Glossary

hence whatever it is attached to or in. Frequently used for locating sewer cameras, and the non metallic pipes.

Target Line                      The buried pipe or cable to be located.

Trace                                Using a locator to following the path of a buried line.

---

Illustrations used in the preparation of this manual will inevitably show some resemblance to similar illustrations from other Manufacturers-some manufacturers have given permission for the use of their graphics (Vivax-Metrotech & Seba) is given credit for these use. This statement is intended to attribute such credit.

---

**Disclaimer:** Product and accessory specification and availability information is subject to change without prior notice.

